

QUANTITY	LENGTH

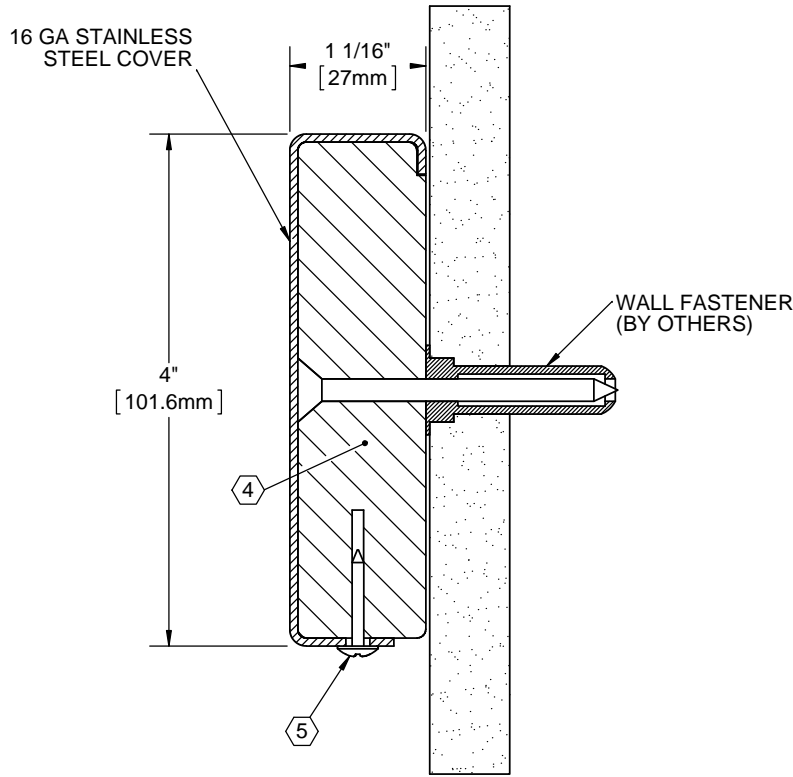

**NOTES:**

- 1. SURFACE MOUNT APPLICATION
- 2. MATERIAL: TYPE 304 STAINLESS STEEL, 16 GAUGE
- 3. FINISH: SATIN #4
- ④ RETAINER: WOOD RAIL
- ⑤ #6 X 3/4" SECURING SCREW, INCLUDED.
- 6. PROVIDED IN 10' CONTINUOUS SECTIONS
- 7. END CAP: #CRSS4-EC
- 8. PARTITION COMPONENTS BY OTHERS.

PROJECT:			
ARCHITECT:			
CONTRACTOR:			
 9300 73rd Avenue North Minneapolis, MN 55428		TITLE:	
		4" SS CRASH RAIL, TYPE 304, 16 GA, SURFACE MOUNT, WOOD RETAINER, #4 FINISH	
NAME	DATE	SIZE	DWG. NO.
DRAWN	DKL	5/7/14	A
RELEASED	PGE	5/7/14	WEIGHT: 2.4 LB/LF
			REV
			A
			SHEET 1 OF 1