

# Seismic Floor Fire Barrier System

Model(s): FLF

## Notes

1. Verify joint width in field prior to ordering system. F140-2IM-02WL 2"(51mm) = minimum joint width of 2" [51mm].
2. Verify that the structural gap and blockout dimensions are in conformance with submittal data before beginning installation. Certification of this product was completed by Intertek Testing Laboratories. Product must be installed in accordance with these Installation Instructions.
3. Ensure joint is plumb and square, also verify soundness of substrate. Repair any spalls or cracks prior to proceeding.
4. For vertical (wall) conditions single sided and double sided blankets are available. For single sided product, ensure drape of blanket faces "potential threat" side of wall.
5. If job site specific conditions exist, these general installation instructions do not take place of an Engineering Evaluation if required. Any modifications made to the product without documented manufacturing direction will void the warranty.

Figure 1

1. Remove product from packaging and identify both male and female ends. Straighten male end if required before installation into expansion joint.

### NOTE:

It is best practice to install all horizontal blankets at each floor continuously with no interruptions. Complete install with verticals.

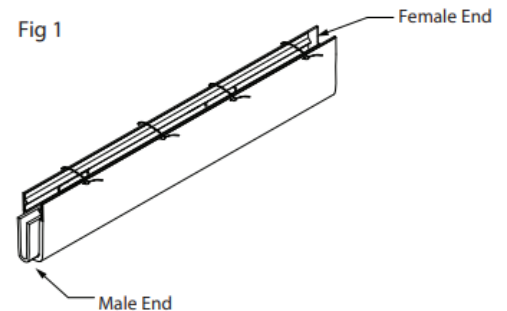

+ Mainten  
Figure 2

2. Before starting a run, cut the male end off of the blanket.

Figure 3

3. With the male end at the starting point of the installation; insert barrier into expansion joint. If starting at an exterior wall, ensure the male end of the stick covers the total wall depth.

TIP: If joint width is smaller than the specified nominal joint width, compress the sides of the blanket evenly using a wood form and clamps. This will allow the F140 blanket to regain its "pill" shape.

Reference detail of joint condition to ensure fire barrier is installed at a depth that does not conflict with any part of the expansion joint system above.

4. While holding only the aluminum frame on one side, cut the zip ties starting on one end working towards the other end.

Figure 4

5. Continue installation by overlapping male side into female side. Ensure the transition connection is snug and free of gaps. Verify the seam overlaps fit tight, with no visible gaps or holes.

NOTE: Installing male to female sections is easier if the female end of the previous barrier is raised out of the expansion joint. Butt the male end into the female end and install into the expansion joint

6. Cut the zip-ties for the current fire barrier and continue installation for the rest of the run.

Figure 5

7. If field conditions require a stick to be cut short, measure the required length from male end and cut the appropriate length.
8. If the removed section of fire barrier contains a spring, be sure to remove that spring from the dropped section, and re-install into provided slots in blanket that will be installed.

NOTE: Maintain a maximum spring spacing of 18" [450mm]

Fig 2

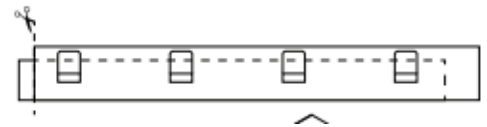

Fig 3

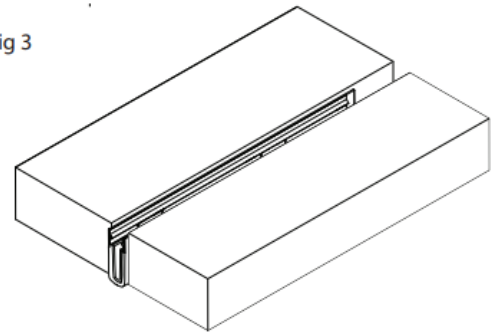

Fig 4

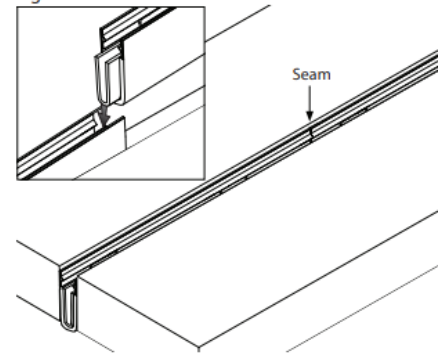
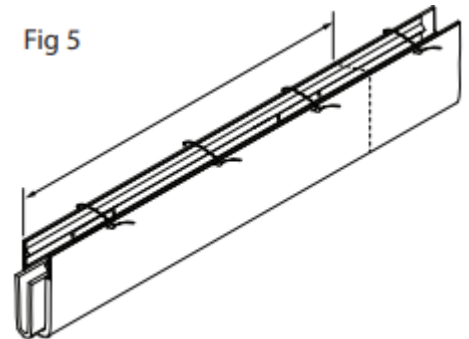

Fig 5



+ Mainten  
 Figure 6

9. When the fire barrier meets a fire rated wall, continue the horizontal fire barrier uninterrupted, or a minimum of the total wall depth to ensure no gaps exist at the intersections. (Reference Figure 8 on next page)
10. If a spring of the horizontal fire barrier is located inside the wall joint, it must be moved to a point before the wall to achieve a proper transition. Maintain a maximum spring spacing of 18" [450mm]
11. Remove 2" [50mm] from each metal flange on the male end of the barrier. Apply UL listed fire caulk liberally to section of the fire horizontal barrier where the vertical stick will intersect, face of the male end, flanges, and interior walls of the slab before installing wall stick. (See Figure 7 for more detail)
12. Insert fire barrier male end down and cut the bottom most zip-tie and continue cutting upward.

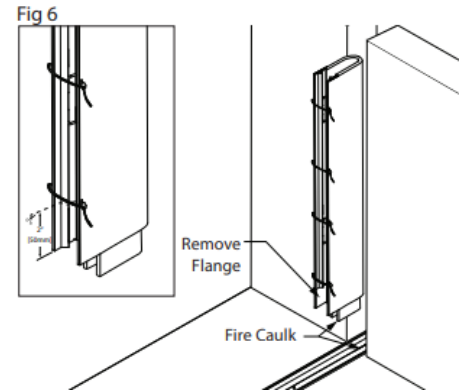
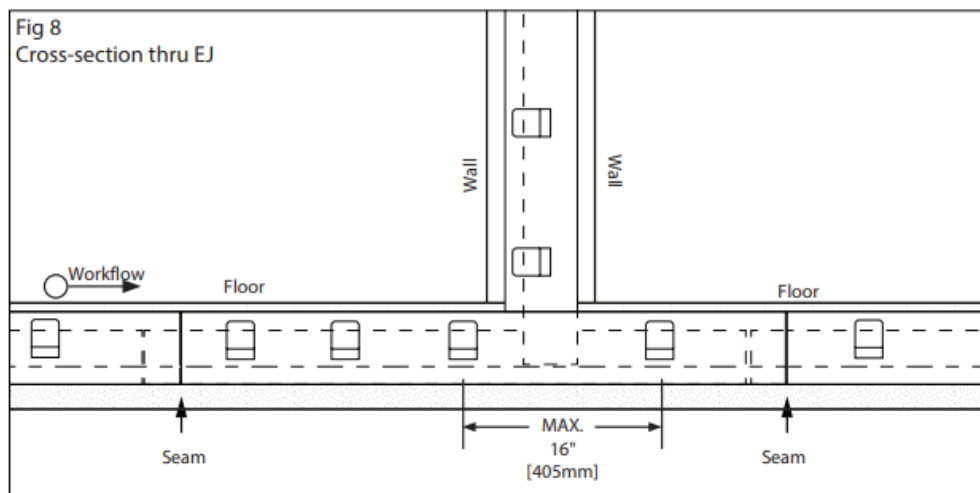
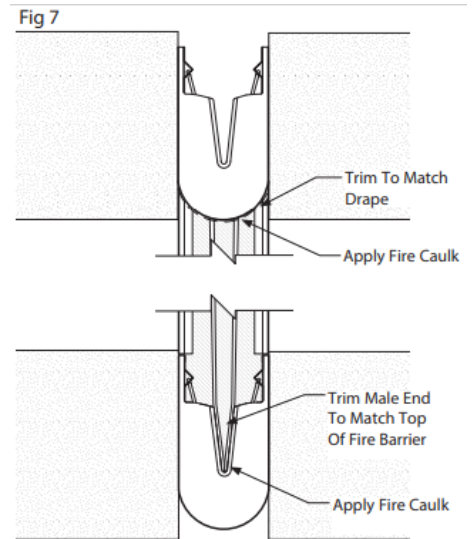

Figure 7

13. Continue vertical installation repeating steps 2-5 for the rest of the run.
14. When intersecting horizontal barrier above, cut final piece to length, and trim female end to match the drape of the horizontal barrier above, applying Fire Caulk to the under side of fire barrier, the portions of the wall around the intersection, and inserting a female end. Ensure there are no gaps at transition.

If the vertical run ends with a full stick, use scrap batting to stuff the female end to match the over all thickness.

15. For perpendicular installs, trim intersecting fire barrier, to match the pre-installed run. Apply fire caulk to trimmed face, and side of pre-installed fire barrier.



+ Mainten  
Fig 9

16. Install continuous run before installing intersecting run.
17. Before installing the intersection. Cut the intersecting end of the F140 assembly to achieve a clean butt end.
18. Reposition the springs so that they are in the nearest spring slot to the cut end of the blanket.
19. Insert the intersecting blanket into the expansion joint. Ensure the cut end of the F140 butts flush with the side wall of the intersecting system.
20. Apply fire caulk to seam at all visible openings.

**FIRE CAULK DISCLAIMER:**

NOTE: Inpro provides 1 or 2 tubes of fire caulk (depending on order size) at no charge. Should additional caulk be required, due to project or site complexity, additional caulk to be provided by others. Install continuous run before installing intersecting  
Install First

Fig 9

