

2		1				
QTY	MODEL	WIDTH	LENGTH	FINISH	LOCATION	

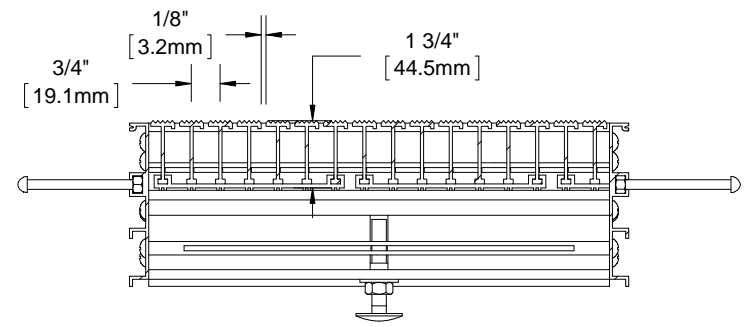

SECTION Y-Y

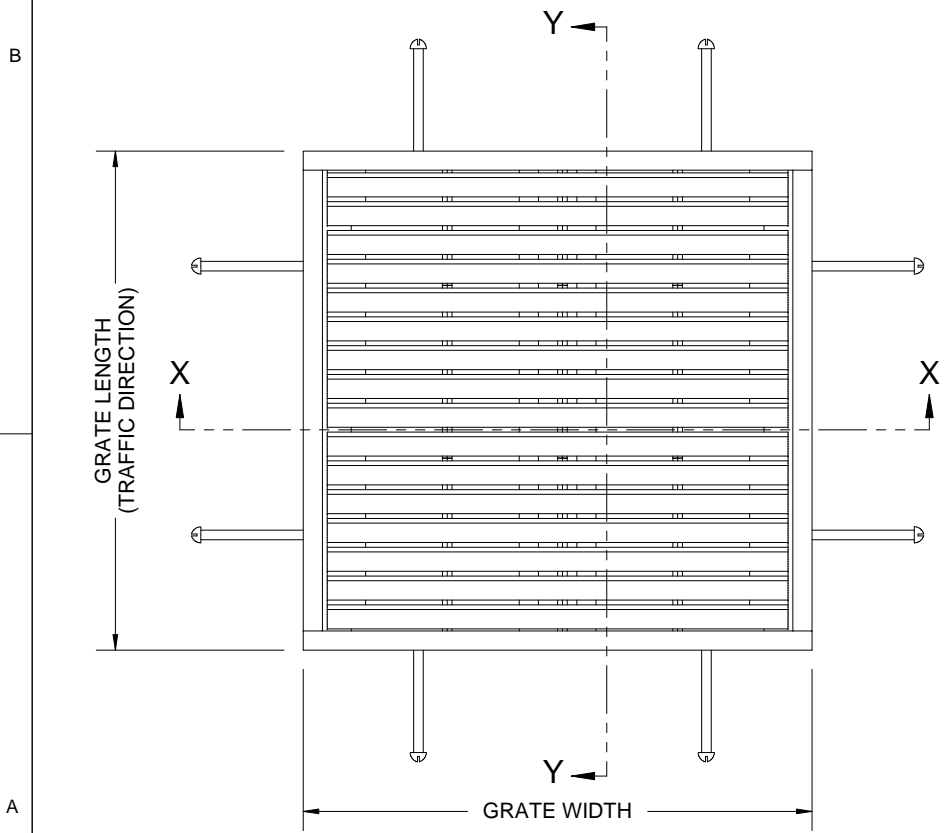
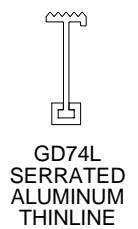
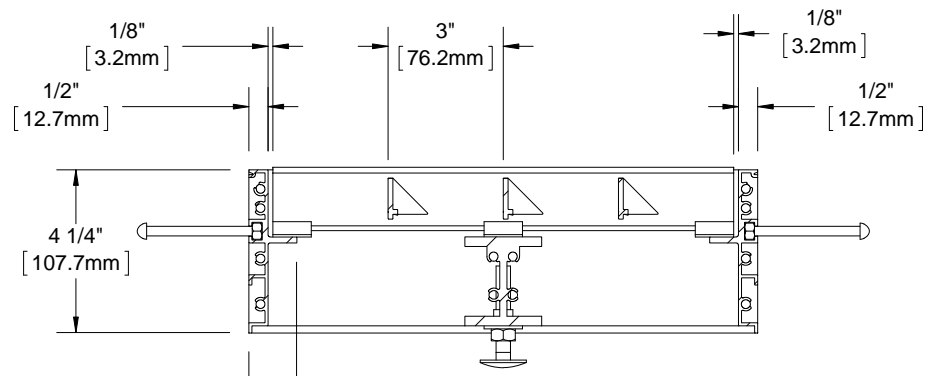

SECTION X-X

- NOTES:**
- STANDARD MAXIMUM SECTION SIZE OF GRATE WIDTH NOT TO EXCEED 8'-0", CUSTOM SECTIONING AVAILABLE
 - FRAME ANCHOR SPACING: 6" FROM CORNERS, 24" MAX
 - VERIFY TRAFFIC DIRECTION AND THAT SECTIONING DOES NOT OCCUR IN A TRAFFIC LANE
 - ALL RAIL COMPONENTS ARE MADE OF 6063-T6 ALUMINUM ALLOY, ALL FRAME COMPONENTS ARE MADE OF 6063-T5 ALUMINUM ALLOY. KEYLOCKS ARE MADE WITH 6061-T6 ALUMINUM ALLOY
 - TREAD RAILS MUST RUN PERPENDICULAR TO TRAFFIC DIRECTION
 - TRAFFIC DIRECTION DIMENSION CAN ONLY BE CHANGE IN 3/4" (19.1 MM) INCREMENTS UNLESS OPTIONAL ALUMINUM FILLER IS INCLUDED
 - GRATE DIMENSION ALLOWS FOR CLEARANCE BETWEEN GRATE SECTIONS AND FRAMES IN THE WIDTH DIMENSION
 - ADDITIONAL INFORMATION CAN BE FOUND IN THE PRODUCT SPECIFICATION AND IS CONSIDERED PART OF THIS TRANSMITTAL.
 - FRAME MODEL NUMBER: FD74D4C

PROJECT:			
ARCHITECT:			
CONTRACTOR:			
 9300 73rd Avenue North Minneapolis, MN 55428		DESCRIPTION:	
		GRATEdesign® 1 3/4" Aluminum Grate with Cast-In, Deep Pit, Aluminum, Frame	
NAME	DATE	SIZE	DWG NO.
DRAWN: DKL	5/12/15	A	GD74L-FD4C
RELEASED: PE	5/12/15	SCALE: NTS	SHEET 1 OF 1
			REV A

PROPRIETARY AND CONFIDENTIAL: THE INFORMATION CONTAINED IN THIS DRAWING IS THE SOLE PROPERTY OF NYSTROM. ANY REPRODUCTION IN PART OR AS A WHOLE WITHOUT THE WRITTEN PERMISSION OF NYSTROM IS PROHIBITED.