

Expansion Joint Systems
Series: EJ-NBW-W

Prepare for Installation

1. Locate the packing slip(s) and shop drawings.
2. Verify that all products listed on the packing slip are included in the package.
3. Check the products for damage. If products are damaged, report a freight claim immediately and leave the products in their packaging. If you sign for products without reporting damage you waive your right to a freight claim and will be responsible for their replacement cost.
4. Read the instructions thoroughly before beginning installation.

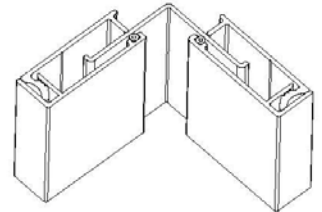

Tools List:

- Drill
- Level
- Chalk Line
- Chop Saw

Parts List:

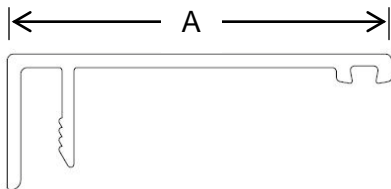

Model	P/N
GASKET	1309

Model	"A"	P/N
EJ-NBW-100W	1.77	29465
EJ-NBW-200W	2.77	29467

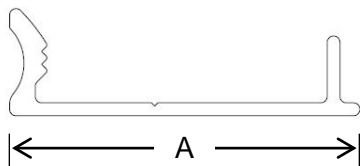

Model	"A"	P/N
EJ-NBW-100W	1.71	29466
EJ-NBW-200W	2.71	29468

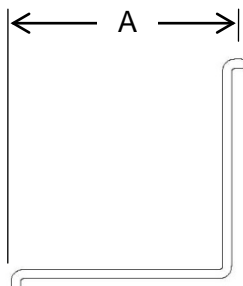

Model	"A"	P/N
EJ-NBW-100W	1.55	29475
EJ-NBW-200W	3.05	29476

Installation:

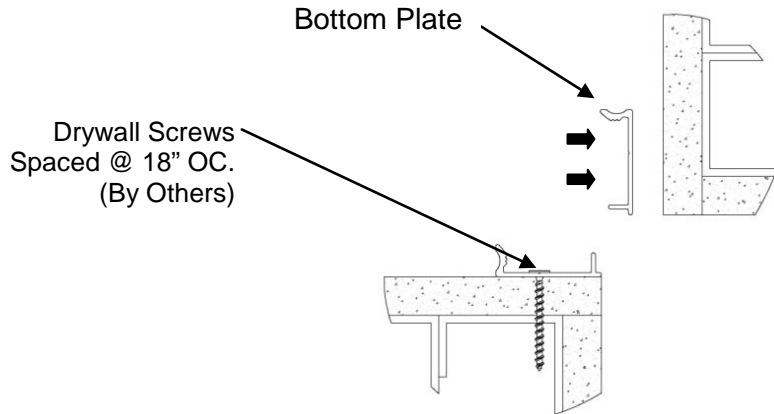

1. Position the bottom plate flush with the inside surface of the joint opening. Field drill holes thru the base extrusion and stud spaced 18 inches on center. After the holes have been drilled, fasten the base extrusion to the wall with drywall screws (by others). If required, fire barrier and moisture barrier should be installed at this time.

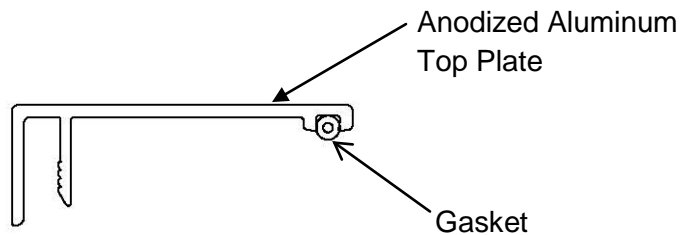

2. Cut Gasket material to length and push the gasket into the groove on the top plate.

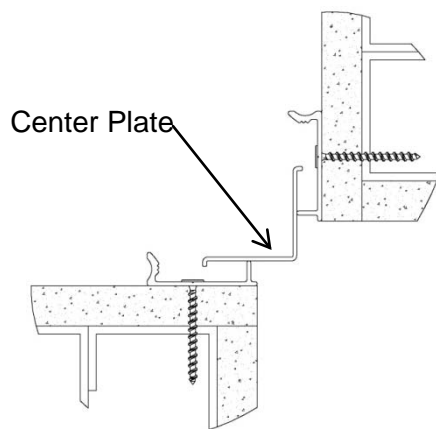

3. Place center slide plate into position against the adjacent bottom plates.

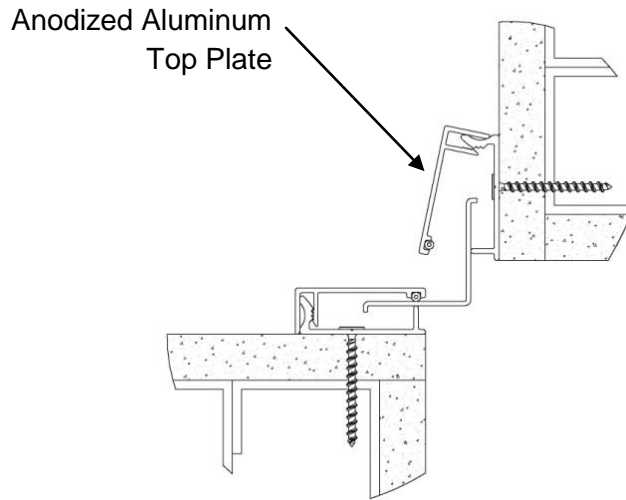

4. Align aluminum top plate with gasket material in front of bottom plate. Using the palm of your hand, gently tap aluminum top plate onto the aluminum bottom plate. It should click into place all along the length of the top plate. Repeat on opposite side. When installing, exercise care not to damage top plate.

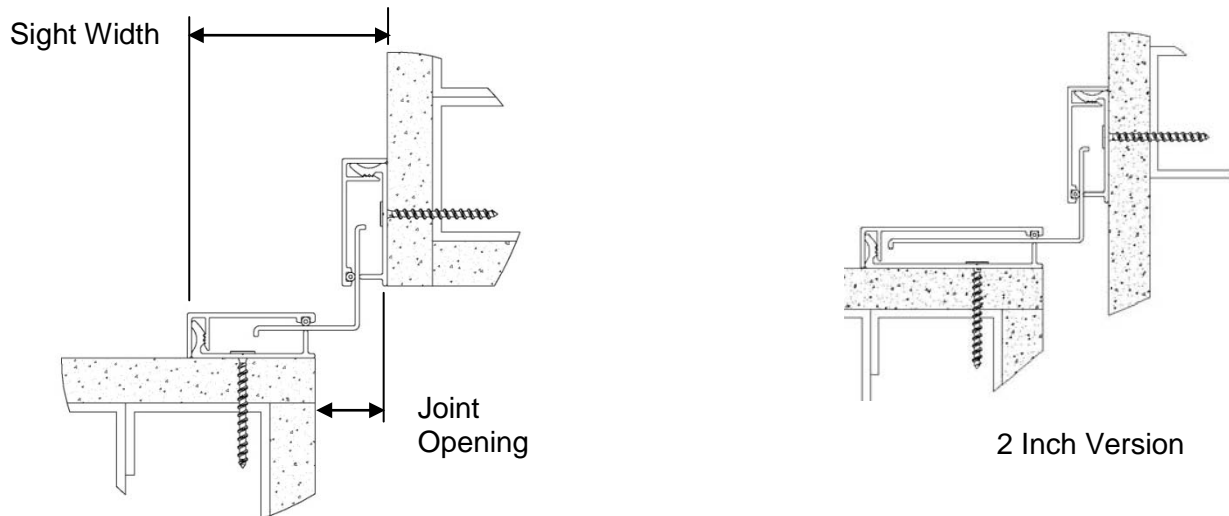
**Operation:**

Expansion joints are designed and built for years of dependable service.

Maintenance:

1. Expansion Joints should be cleaned routinely.
2. Exposed surfaces can be cleaned with a mild water-based cleaning solution. Wipe clean with a sponge or soft cloth.
3. Do not use steel wool or powdered abrasive cleaners as they will scratch the aluminum surface.
4. If any questions arise during the operation or maintenance of the products, please feel free to call our toll-free number for assistance, 1-800-547-2635 for technical support.