

Hurricane Roof Hatch

Model(s): RHH

GENERAL DESCRIPTION

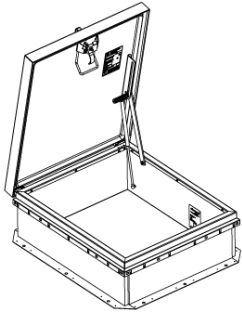

Roof Hatch products provide safe and convenient access to roof areas using interior ladders, alternating tread devices and stairs. Roof hatches are designed and built for years of safe, convenient access to roof top areas on commercial buildings.

The following are general instructions for installing, operating and maintaining Hurricane Roof Hatches.

Introduction + Safety

Please read the complete instructions carefully before beginning any work. To ensure proper installation and performance of the roof hatch the following actions must be completed by the installing contractor. Failure to do so will affect product warranty.

GENERAL SAFETY PRECAUTIONS Improper selection, installation, or use can cause personal injury or property damage. It is solely the responsibility of the user, through its own analysis to select products suitable for their specific application requirements, ensure they are properly maintained, and limit their use to its intended purpose. Follow proper local, state and federal regulations for proper installation and operation requirements.

Transportation + Storage

- Inspect all shipments and materials for missing or damaged components and hardware.
- Material must be stored in a clean, dry location.

INSTALLATION

Roof hatches are intended for commercial building applications. Because condensation may occur as a natural result of humidity levels and temperature variations between indoor and outdoor temperatures, residential type applications are not recommended.

The exterior of the roof hatch will have a label with an arrow that says EXIT THIS SIDE. The arrow will point to the intended location of the top of the ladder, ship stair, alternating tread or service stair.

Roof hatch products may be installed on a flat or sloping roof with up to a 7:12 pitch for single point latch units and 3:12 pitch for 2-point latch units. When installed on a slope, the hinge side should run parallel with the slope.

1. Place the roof hatch over the existing opening in the roof. The roof rough opening dimensions are equal to hatch dimensions as measured from the inside curb to inside curb. For example, a 36 inch by 30-inch fixed ladder access hatch will have a rough opening of 36 inches by 30 inches.
2. The roof hatch curb flange comes with two (2) types of mounting holes to accommodate multiple fastening methods practiced and accepted at a local level.

- a. Mark the pre-drilled diameter holes from the mounting flange through the roof deck or a concrete curb. Reference table below for hardware and placement. Drill for installation of anchors or other fasteners (provided by others). Bolt or otherwise fasten roof hatch curb flange to roof deck, figure 1.

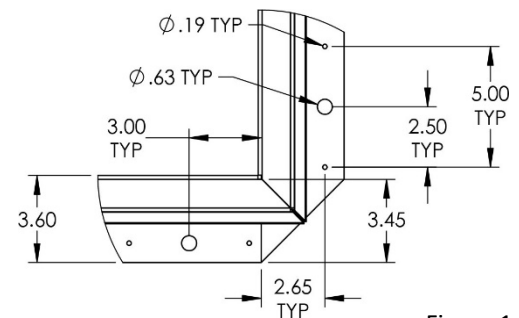

Figure 1

Curb Type	Fasteners
Wood, figure 2a Wood S.G. = 0.55 min	<ul style="list-style-type: none"> ○ 3/8-inch diameter 316 lag bolts (Fy=65ksi) ○ Southern Pine (G=0.55 min), predrill as recommended ○ Penetration = 1-3/4-inch min of 1-1/2 inch of threads to be engaged into wood ○ Spacing: 3 inches ○ Edge Distance: 1-1/2-inch min ○ End Distance: 6-inch min
Steel, figure 2b Fy = 33Ksi: min Thickness = 0.105-inch min	<ul style="list-style-type: none"> ○ 5/16-inch diameter stainless steel fasteners min. ○ Self-drilling, self-tapping or thru bolts ○ 300 series stainless steel, cond. CW, Fy65ksi ○ 0.105 thread engagement min.
Concrete, figure 2c 3000 psi min	<ul style="list-style-type: none"> ○ 3/8-inch diameter stainless steel Kwik bolt TZ wedge anchor 316 stainless steel ○ Eff. Embedment depth: 2-inch min ○ Install Depth: 2.313 min ○ Edge Distance: 6-inch min ○ Spacing: 4-1/2-inch min ○ Min. Slab Thickness: 4 inch – normal wt. ○ Cracked concrete compressive strength: f'c = 300psi

****Install per manufacturer's instructions****

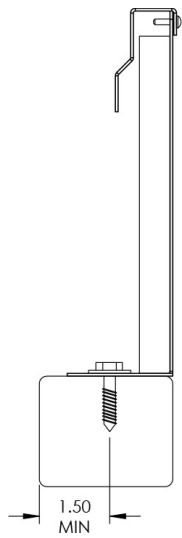

Figure 2a

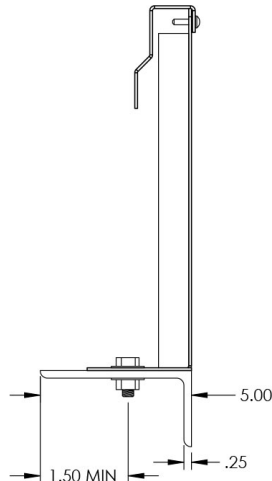

Figure 2b

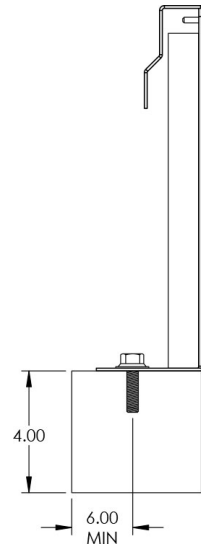

Figure 2c

3. Install roofing material up to and surrounding the roof curb, and under the counterflashing at the top of the curb. Use the EZ tab feature, *figure 3*, to provide additional mechanical support to hold and secure roofing membrane. Lap and seal all joints in roofing material to provide a weather-tight seal.

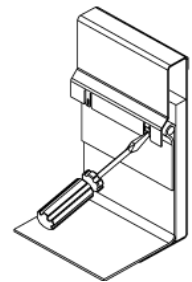

Figure 3

OPERATION

Roof hatches are designed and built for years of dependable roof access. To meet the demands of an exterior application, the doors are manufactured from steel or aluminum. The curb and cover are insulated and have a continuous extruded thermal EPDM gasket that creates a weather resistant seal. The standard curb comes with a counterflashing incorporating EZ tabs to assist with mechanically securing roofing material/membrane. The steel roof hatch comes standard with a finished baked on powder coat paint that offers the best corrosion protection in the industry.

Single Point Latch (*figure 4*)

Open

1. Rotate the slam latch handle ③ to unlatch.
2. Push yellow handle ② to fully open hatch cover until hold open arm locks.

Close

1. Pull red grip hold open arm handle ① forward to disengage.
2. Descent the ladder, grab the yellow handle ② to slam the hatch closed.

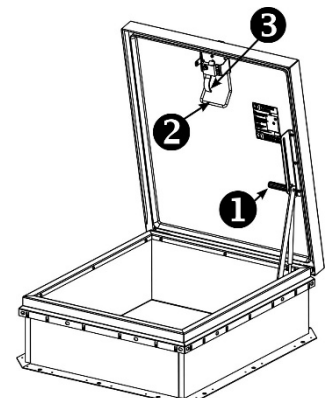

Figure 4

3. Lock using a padlock hasp, if required.

2-Point Latch (figure 5)

Open

3. Rotate the slam latch handle ③ to unlatch.
4. Push handle ② to fully open hatch cover until hold open arm locks.

Close

1. Pull red grip hold open arm handle ① forward to disengage.
2. Descent the ladder, grab the yellow handle ② to slam the hatch closed.
3. Lock using a padlock hasp, if required.

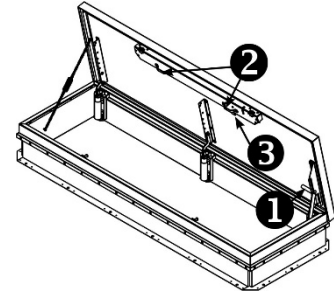

Figure 5

Note: Larger hatches, especially over 72 inches in length, may need two people to ensure proper closure.

MAINTENANCE

- Roof hatches should be manually operated once a year to check performance.
- Lubricate moving parts such as hinges and latches with a silicone spray lube as required to maintain a smooth opening and closing of the door. Do not use regular lubricating oil as it can attract dust and grit.
- Non-moving parts can be cleaned with a mild soap or dishwashing detergent and water solution.
- Gaskets can be cleaned with a clean, damp, lint-free cloth. Do not apply mineral oils, vinyl dressings, or other lubricants to the gasket as they can cause the gasket to break down over time.

QUESTIONS?

For more information on installation, repair or replacement, please visit www.Nystrom.com or call 800.547.2635.