

Seismic Floor Series
Model(s) EJ-SFC
Horizontal Expansion Control Systems

The following installation procedure is very important and must be fully understood prior to beginning any work. To ensure proper installation and performance of expansion joint system the following actions must be completed by the installing contractor. Failure to do so will affect product warranty.

- 1) Carefully read and understand installation procedure. Contact Technical Service Department for product assistance.
- 2) Inspect all shipments and materials for missing or damaged components and hardware. Contact Customer Service with order number and invoice for prompt assistance.
- 3) Inspect substrate or adjacent construction for acceptance before beginning work. Report unacceptable construction to the project manager for scheduled repair work.

Standard Components

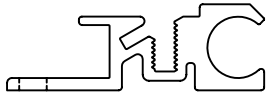

Aluminum base assembly
(P/N 15804)



1/4" x 1 1/4" CSK flat head
machine screw (P/N 5621)

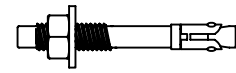

1/4" x 2 1/4" Hilti Kwik Bolt
with nut and washer
(P/N 6581)

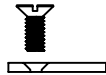

Aluminum extension (P/N 12039B)
with 1/4" x 5/8" CSK flat head
machine screw (P/N 5620)



1/4" x 2" CSK flat head threaded
concrete anchor (P/N 5621)
(Corner Condition Only)

Components shown below vary in size depending on model of system

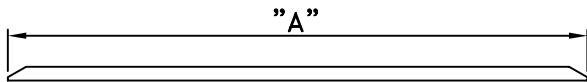

3/16" thick center slide plate
(Refer to chart for Part Numbers)

Model	P/N	"A"	Model	P/N	"A"
EJ-SFC-200	12030	3 1/2"	EJ-SFC-1000	12026	15 1/2"
EJ-SFC-400	12032	6 1/2"	EJ-SFC-1200	12027	18 1/2"
EJ-SFC-600	12033	9 1/2"	EJ-SFC-1800	12028	27 1/2"
EJ-SFC-800	12025	12 1/2"	EJ-SFC-2400	12029	36 1/2"

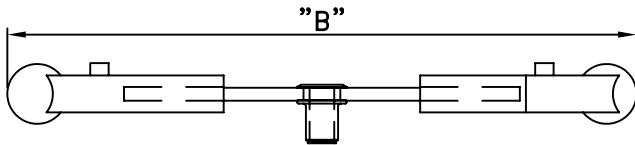

Self-centering bar
(Refer to chart for Part Numbers)

Model	P/N	"B"	Model	P/N	"B"
EJ-SFC-200	11089	7"	EJ-SFC-1000	15630	18 3/8"
EJ-SFC-400	15642	7 3/8"	EJ-SFC-1200	15631	22 3/8"
EJ-SFC-600	15643	12 3/8"	EJ-SFC-1800	15644	32 3/8"
EJ-SFC-800	15630	18 3/8"	EJ-SFC-2400	15604	38 3/8"

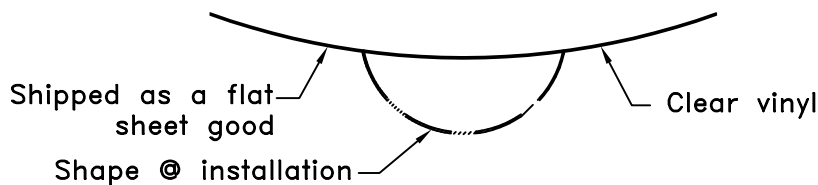

Optional Moisture Barrier

Shown below are extra components needed for floor-to-wall installation.

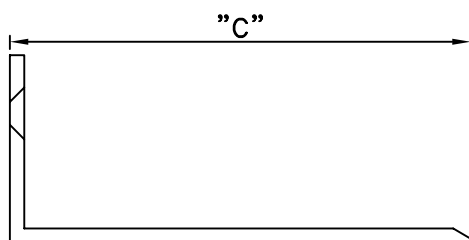

3/16" Aluminum Corner cover plate
(Refer to chart for Part Numbers)

Model	P/N	"C"	Model	P/N	"C"
EJ-SFC-200	11089	7"	EJ-SFC-1000	15630	18 3/8"
EJ-SFC-400	15642	7 3/8"	EJ-SFC-1200	15631	22 3/8"
EJ-SFC-600	15643	12 3/8"	EJ-SFC-1800	15644	32 3/8"
EJ-SFC-800	15630	18 3/8"	EJ-SFC-2400	15604	38 3/8"

Optional Moisture Barrier

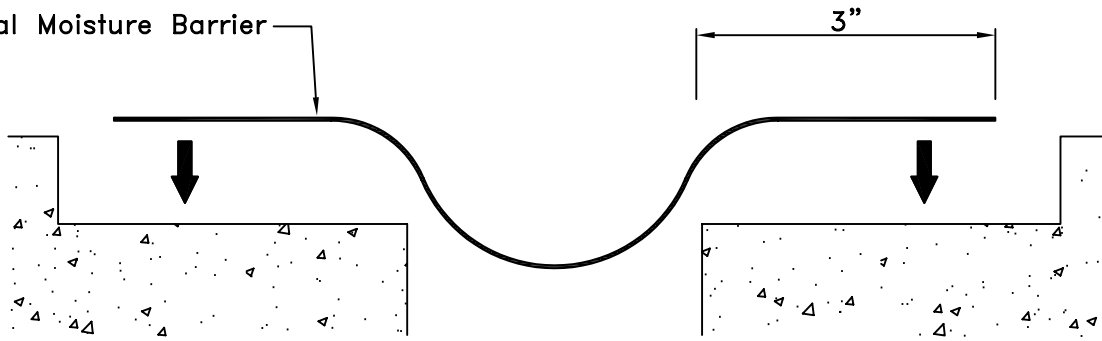

1

(optional)
Position moisture barrier in to blockout. Maintain proper overlap and temporarily affix with duct tape (if required).

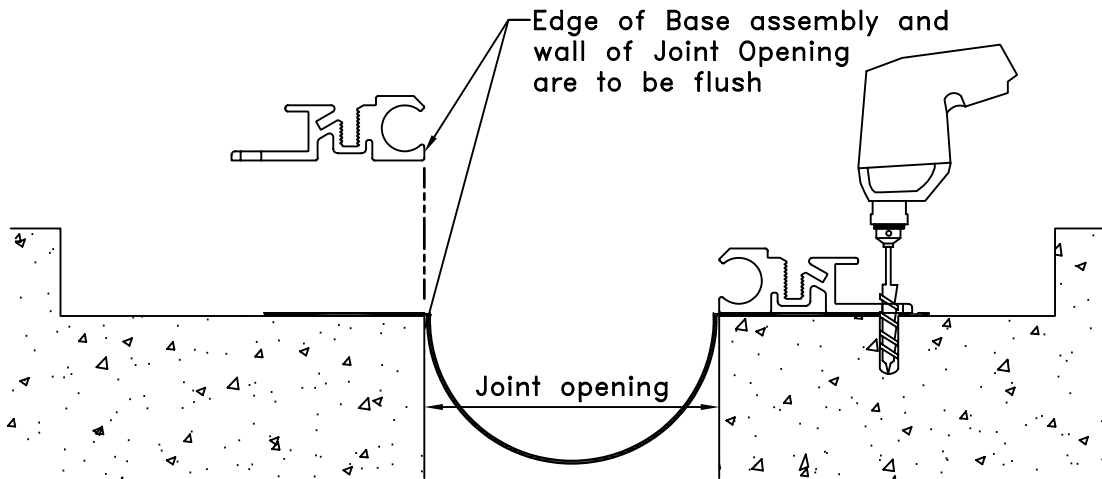

2

Position base member on block out so cavity of base member is flush with edge of opening. Using base member as a template and with its position fixed, drill hole for 1/4" x 2-1/4" hilti bolt to proper depth. Clean out holes.

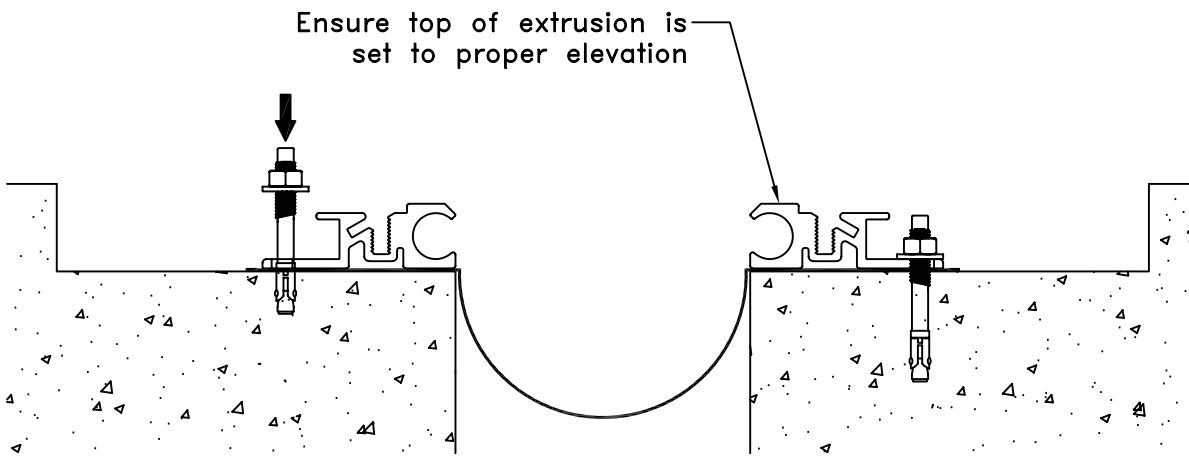

3

Follow hilti's recommendations for proper anchor installation. Remove all debris from moisture barrier by utilizing shop vac. Caution: do not install all base members prior to reviewing step 6.

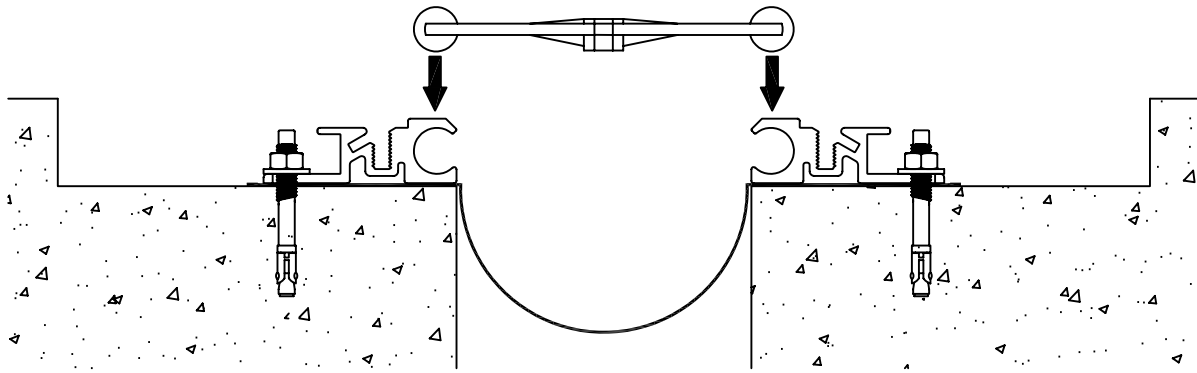

4

As work progresses with placement of base members, install self-centering bars by sliding the spherical ends of the bars into and through the circular cavities of the base members. Set at an approximate spacing of 18" O.C. Ensure that the "top" indicator is facing up and that all bars are in same orientation.

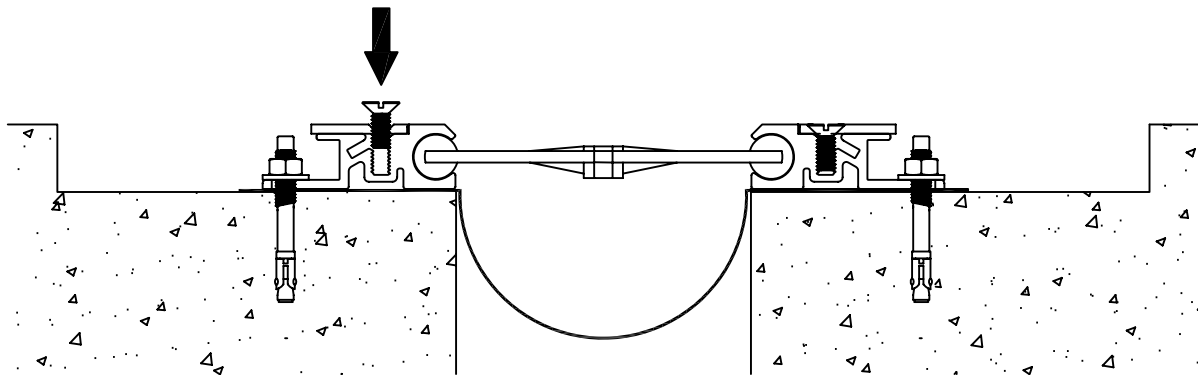

5

Attach aluminum extension to base member with 1/4" x 5/8" CSK flat head machine screw.

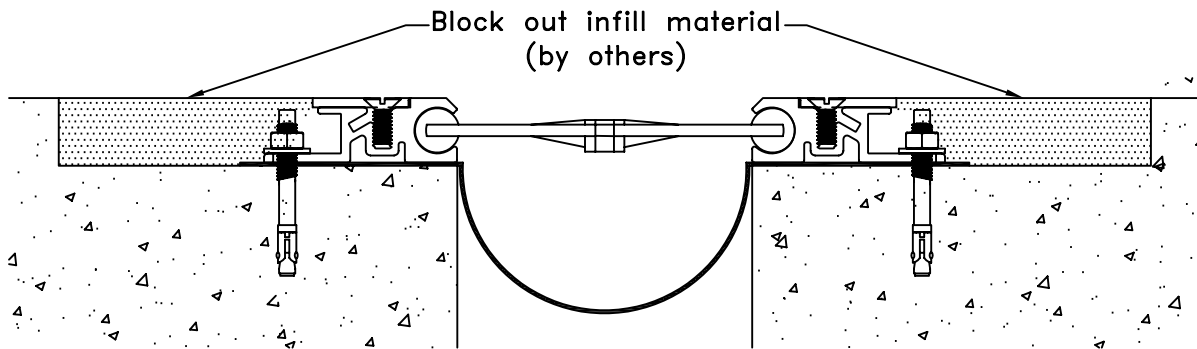

6

Fill block out with high quality non-shrink cementitious filler material. Use Grout or equivalent filler for infill material. Protect surfaces during placement of filler material.

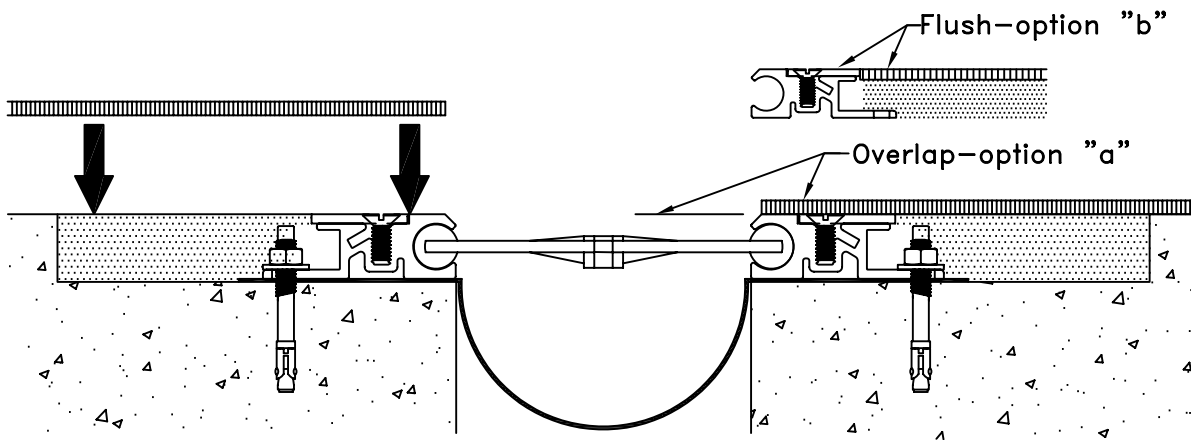

7

Install flooring material. Ensure flush installation with top of expansion joint system. Caution – contact flooring manufacturer to discuss product application and procedure for proper installation. Check contract documents to determine if finish floor material is set flush with or overlaps top of base member.

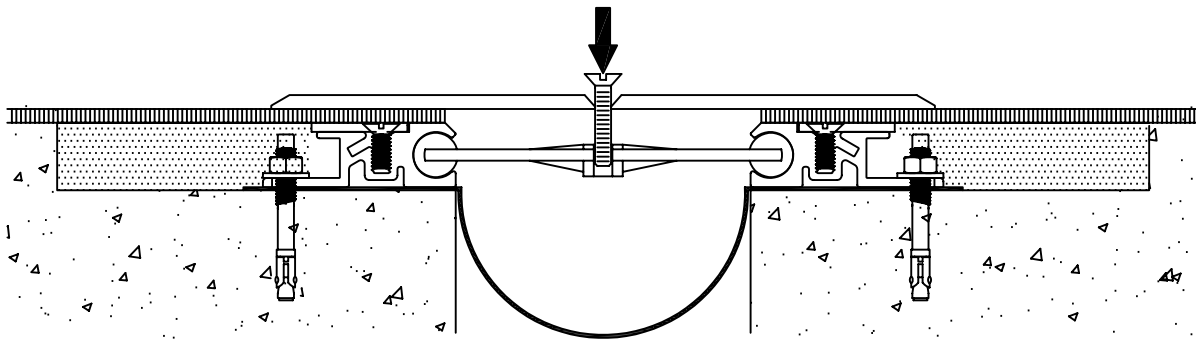

8

Position the center slide plate over expansion opening. Align pre-drilled holes in slide plate with threaded insert in self-centering bars. Fasten with 1/4" x 1-1/4" CSK flat screw. Tighten to create measurable tension in the bar. Note: with option "a" do not over tighten.

Floor to Wall

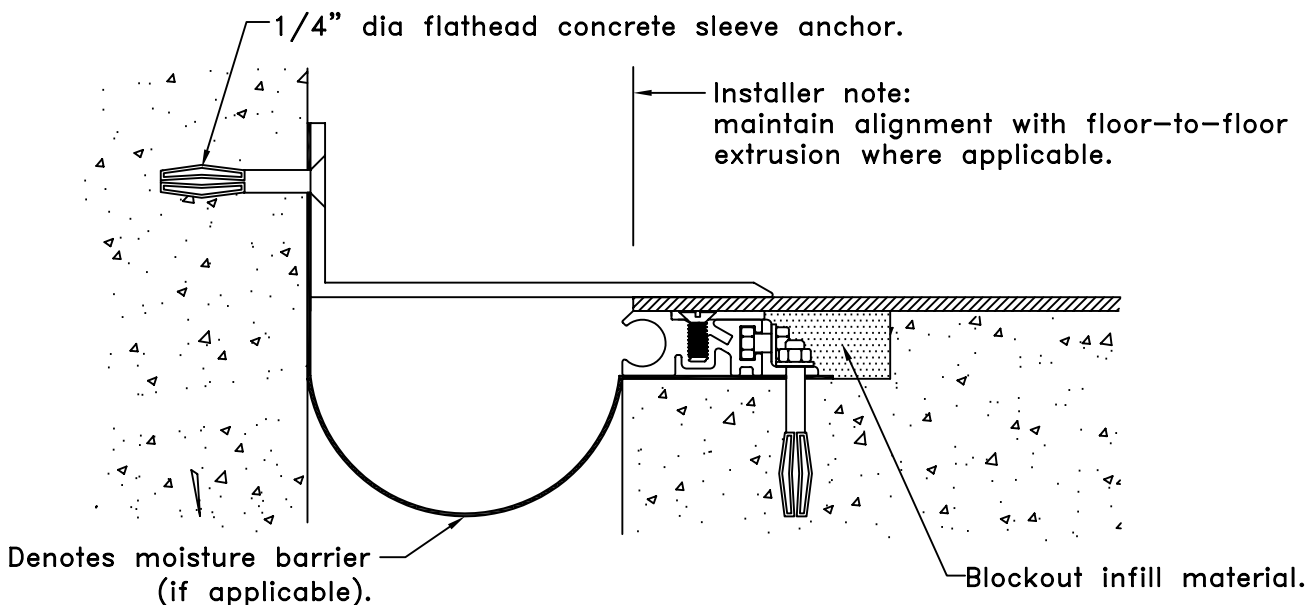

Follow the same procedure for floor-to-wall, except use cover plate for floor-to-wall condition and 1/4" CSK concrete flathead expansion anchor. Contact customer service should wall construction dictate alternate style anchor.