

B

B

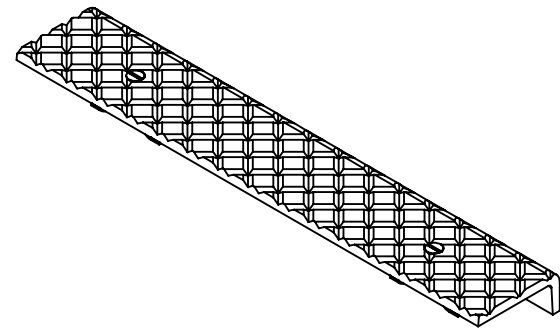
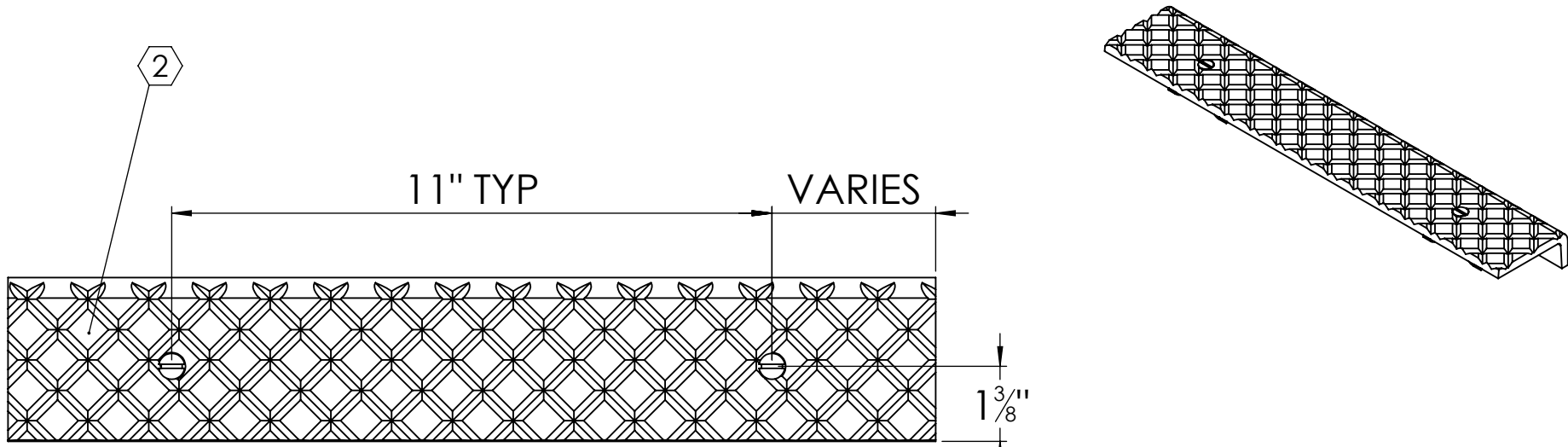

A

A

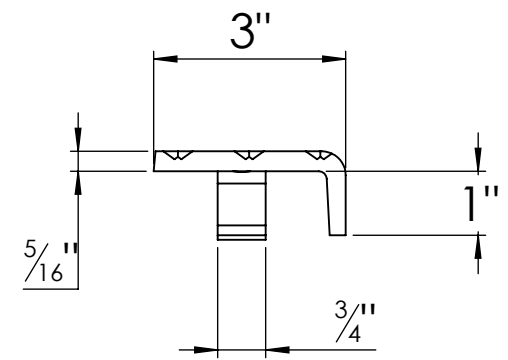
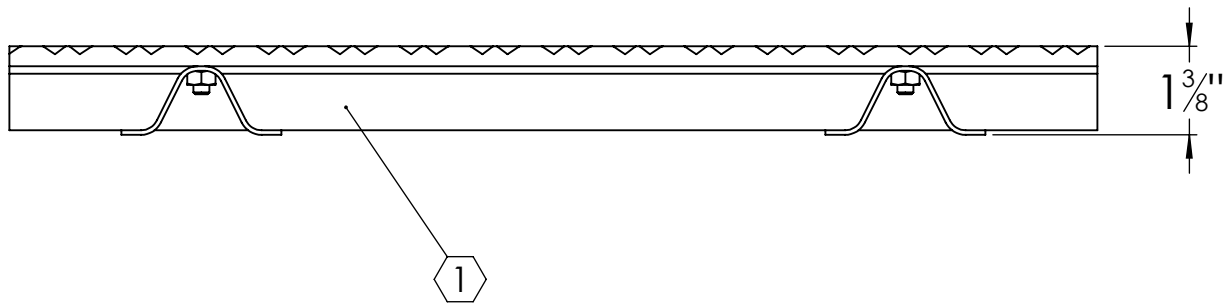

**SPECIFICATIONS:**

- ① BASE: 319 CAST ALUMINUM
- ② ABRASIVE: SILICON CARBIDE ABRASIVE , CROSSHATCH PATTERN 1/8" DEEP
- 3. FINISH: SAND CAST
- 4. POURED CONCRETE STAIRS: NOSING SHALL TERMINATE NO MORE THEN 3" FROM END OF STEPS
- 5. LENGTH: 6" MINIMUM 6'-0" MAXIMUM
- 6. WING ANCHORS: STANDARD FOR POURED CONCRETE APPLICATIONS; STEEL ANCHORS AND STAINLESS STEEL HARDWARE

LENGTH ±1/8	QTY

PROJECT:			
ARCHITECT:			
CONTRACTOR:			
QTY:			
PART#:		STCA-L3W	
 9300 73rd Avenue North Minneapolis, MN 55428		TITLE: Stair Tread, Cast Series	
		3", Cast Aluminum Crosshatch Long Nosing for Pan, Wing Anchor	
NAME	DATE	SIZE	DWG. NO.
DRAWN SJB	3/31/11	A	STCA-L3W
RELEASED DWO	3/31/11	WEIGHT: 1.27 LB/FT	SHEET 1 OF 1

PROPRIETARY AND CONFIDENTIAL: THE INFORMATION CONTAINED IN THIS DRAWING IS THE SOLE PROPERTY OF NYSTROM. ANY REPRODUCTION IN PART OR AS A WHOLE WITHOUT THE WRITTEN PERMISSION OF NYSTROM IS PROHIBITED.