

B

B

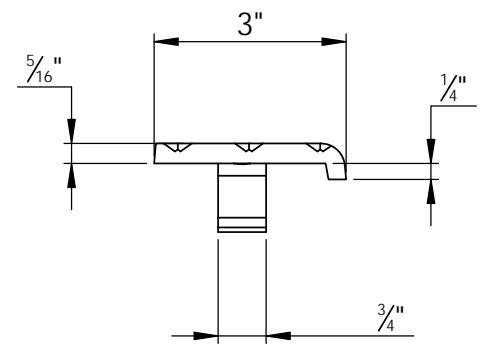
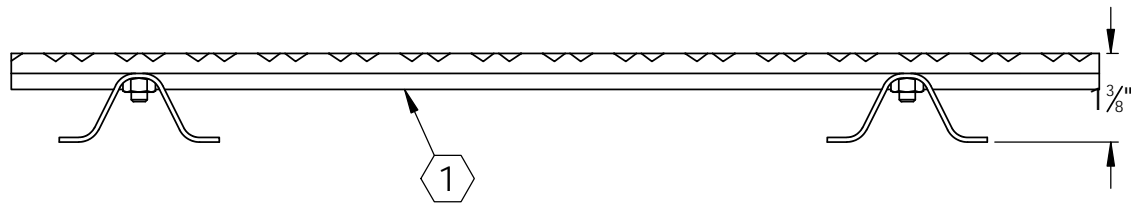
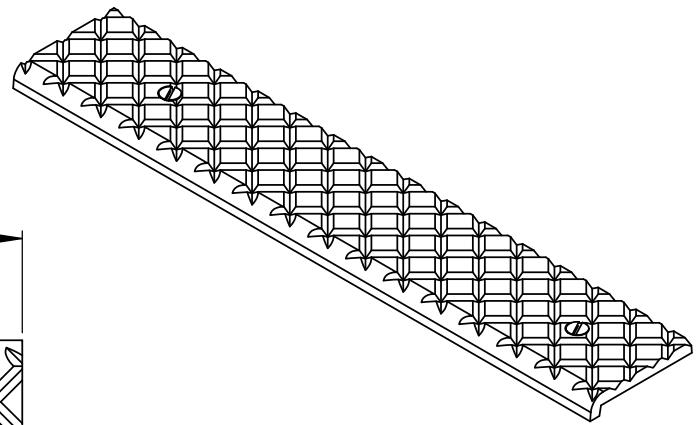
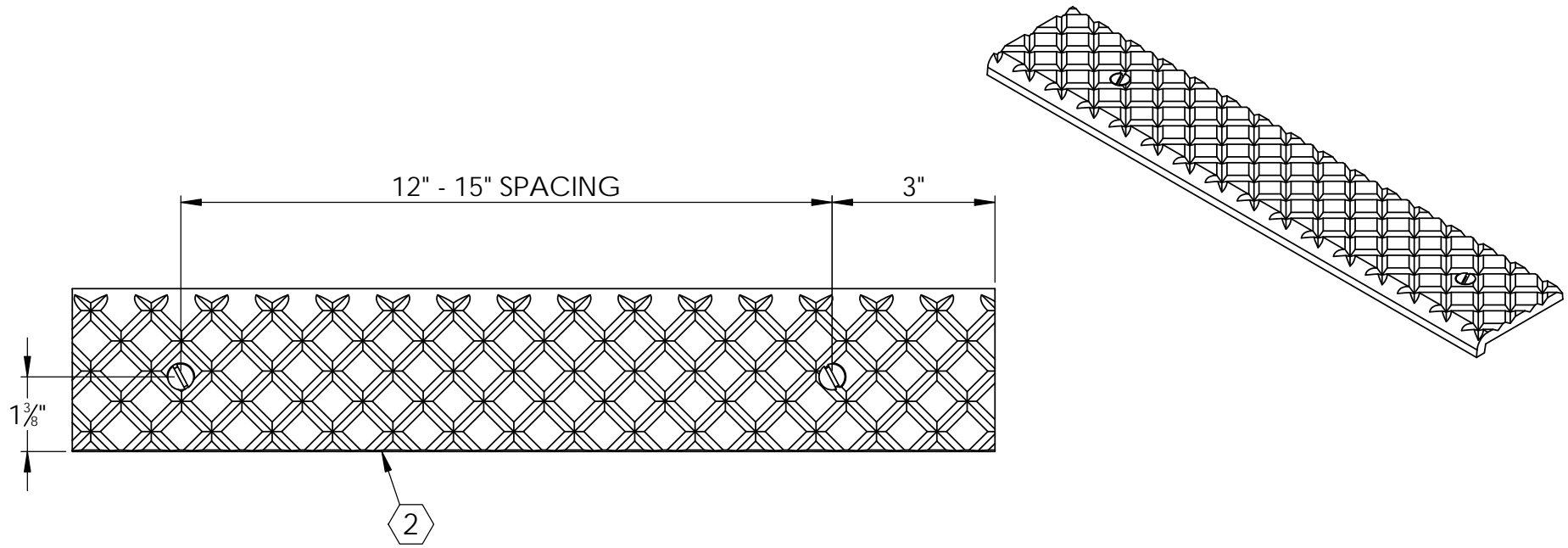

A

A

SPECIFICATIONS:

- ① BASE: 319 CAST ALUMINUM
- ② ABRASIVE: SILICON CARBIDE ABRASIVE , CROSSHATCH PATTERN 1/8" DEEP
- 3. FINISH: SAND CAST
- 4. PAN STAIRS WITH CONCRETE: NOSING SHALL TERMINATE NO MORE THAN 1/16" FROM SIDE OF STEPS
- 5. LENGTH: 6" MINIMUM 6'-0" MAXIMUM
- 6. WING ANCHORS: INSTALLED, STEEL ANCHORS AND STAINLESS STEEL HARDWARE

LENGTH ±1/8	QTY

PROJECT:			
ARCHITECT:			
CONTRACTOR:			
QTY:			
PART#:		STCA-P3C	
 9300 73rd Avenue North Minneapolis, MN 55428		TITLE:	
		STAIR TREAD, CAST SERIES 3", CAST ALUMINUM CROSSHATCH SHORT NOSING FOR PAN, WING ANCHOR INSTALLED	
NAME	DATE	SIZE	DWG. NO.
DRAWN	DKL	10/13/23	A
RELEASED	GLN	10/13/23	STCA-P3C
WEIGHT: 1.20 LB/FT			REV C

PROPRIETARY AND CONFIDENTIAL: THE INFORMATION CONTAINED IN THIS DRAWING IS THE SOLE PROPERTY OF NYSTROM. ANY REPRODUCTION IN PART OR AS A WHOLE WITHOUT THE WRITTEN PERMISSION OF NYSTROM IS PROHIBITED.