

5-1/2" CRASH RESISTANT HANDRAIL

Model(s):HRVE55C/HRVE55C-TG/HRVE55C-AS

GENERAL DESCRIPTION



Nystrom's Standard 5-1/2" Handrail is constructed to withstand impact with built-in crash protection. The sturdy mounting brackets maintain wall clearance and stability while providing support in medium- to high-impact areas. End and corner caps are available as semi-rigid plastic. Optional reveals, available for both foam cushion and semi-rigid plastic end and corner caps, provide additional design options.

Introduction + Safety

Please read the complete instructions carefully before beginning any work. To ensure proper installation and performance of the Expansion Joint, the following actions must be completed by the installing contractor. Failure to do so will affect product warranty.

GENERAL SAFETY PRECAUTIONS Improper selection, installation, or use can cause personal injury or property damage. It is solely the responsibility of the user, through its own analysis to select products suitable for their specific application requirements, ensure they are properly maintained, and limit their use to its intended purpose. Follow proper local, state and federal regulations for proper installation and operation requirements.

Transportation + Storage

- Inspect all shipments and materials for missing or damaged components and hardware.
- Material must be stored in a clean, dry location.

INSTALLATION

1. Lay out the work to be completed, including all component parts, along the base of the wall. Check the material for any damage that may have occurred during shipment and/or handling at the job site.
2. Snap a chalk line at the proper location on the wall to ensure a level installation. Chalk line should be calculated to the center line of the mounting bracket wall fasteners.

3. Place the retainer in the proper position on the chalk line and mark hole locations using the proper bit size for fasteners.
 - Note: All crash rail and handrail material is provided in 20'-0" stock lengths to be cut in the field. A 80-100 tooth, carbide tip saw blade or equivalent is recommended for cutting the material to minimize chipping. The aluminum retainer has been supplied in stock lengths, it will be necessary for it to be field-cut. Determine the allowances necessary for door jambs, corner conditions, etc. Cut retainer to proper length. Drill 9/32" (holes at I.D. mark on retainer 3" in from each end and all intermediate locations not to exceed 32" O.C.
4. Attach connector plates to ends of retainer using two #8 x 1" hex head screws
5. Attach ends and corners using two #8 x 1" hex head screws. If reveals are being used, insert reveal between end/corner and connector plate before attaching.
6. Attach splice joints with 3/16" x 1-1/2" hex head machine bolts, washers, and nuts.
7. Mount assembly to wall using 1/4" x 4" fastener (not included). Feed fastener through retainer and mounting bracket. Attach and feed through wall. Tighten securely.
 - Note: Prior to installation of the cover, make sure that all fasteners are secure and properly seated.
8. Hold the cover at an angle and place the top of the cover behind the top of the retainer. Make sure that the cover is placed in the proper position and snap-fit the cover onto the aluminum retainer by placing hands downward and applying pressure with the heel of each hand to force the cover onto the retainer. Continue along until the complete length of the cover is securely installed.

Assembly drawing shown for model HRVE55C

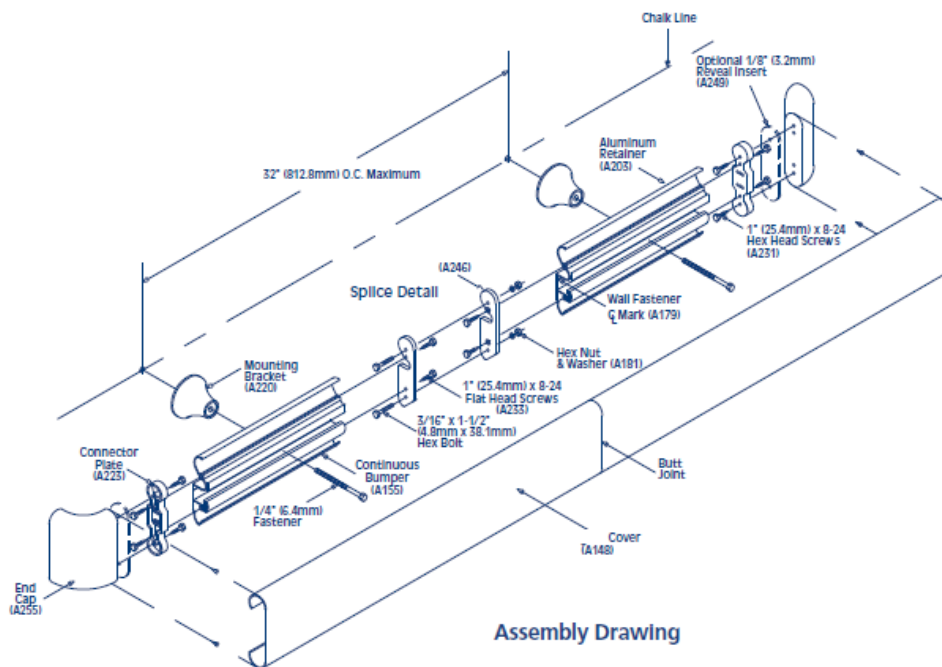

Models: HRVE55C, HRVE55C-TG, HRVE55C-AC

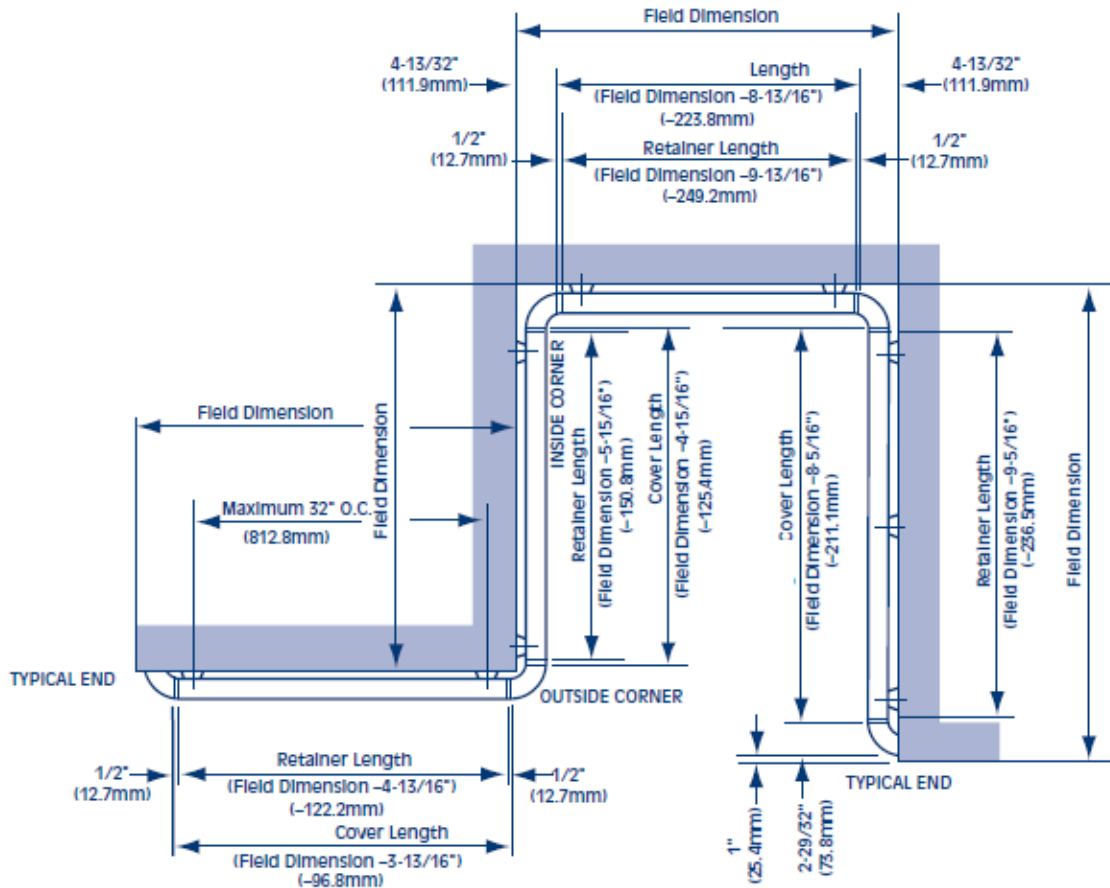

- Note: If incorporating reveals at ends and corners, deduct an additional 1/4" 1/8" at each end when determining cover and retainer lengths.

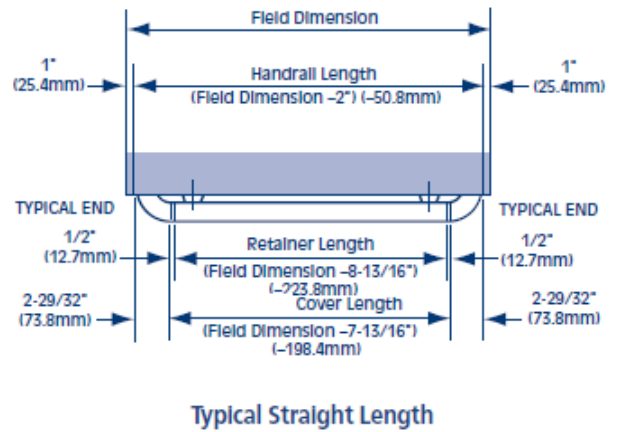
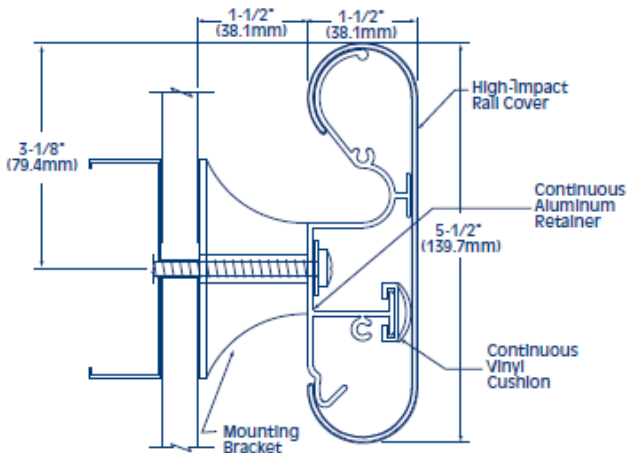

Typical Straight Length

OPERATION

Crash Rails are designed and built for years of dependable service.

MAINTENANCE:

1. Use mild detergent to clean soiled surfaces. Pen marks, paint and graffiti generally wash off easily with mild soap and water. Completely rinse the surface with clean water when complete.
 - Note: Powdered cleansers and bleach cleaners should be used with care as they may leave a residue embedded in the cover surface. Properly rinsing with clean water will remove any residual residue.
 - Tough marks or stains may require a heavy duty cleaner such as "Crown Anti-Vandal Spray" or "DWR-II". These specialized spot cleaners should only be used on small areas and tested for color fastness prior to applying in a highly visible area. Rinse thoroughly with clean water to remove the residue from these cleaners.

QUESTIONS?

For more information on installation, repair or replacement, please visit www.Nystrom.com