

SECTION A-A

SECTION B-B

ROUGH OPENING: " X " "  
 CLEAR OPENING: " X " "  
 DEGREE OF OPENING: " "  
 # LATCHING POINTS: "

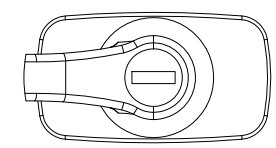

DETAIL F

NOTES:

- ① **FRAME:** 6063-T5 Ext Aluminum, Mill Finish
- ② **DOOR:**
- ③ **HINGE:**
- ④ **GASKET:** EPDM Self-Adhesive, Continuous Four Sides
- ⑤ **INSULATION:** Foam Insulation, 2-1/4lb Density, 12 R-Value
- ⑥ **LATCH:** NO LATCH w Interior Handle
- ⑦ **LOCK:** Lockable Handle w Interior Handle

**FLORIDA PRODUCT APPROVAL  
 NUMBER FL21058**

PROJECT:				
ARCHITECT:				
CONTRACTOR:				
QTY:				
PART#:				
<b>nystrom</b>	TITLE:			
9300 73rd Avenue North, Minneapolis, MN 55428				
NAME	DATE	SIZE	DWG. NO.	REV
DRAWN		A		A
RELEASED			WEIGHT: 5.9	SHEET 1 OF 2

PROPRIETARY AND CONFIDENTIAL: THE INFORMATION CONTAINED IN THIS DRAWING IS THE SOLE PROPERTY OF NYSTROM. ANY REPRODUCTION IN PART OR AS A WHOLE WITHOUT THE WRITTEN PERMISSION OF NYSTROM IS PROHIBITED.

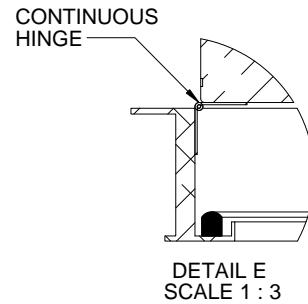
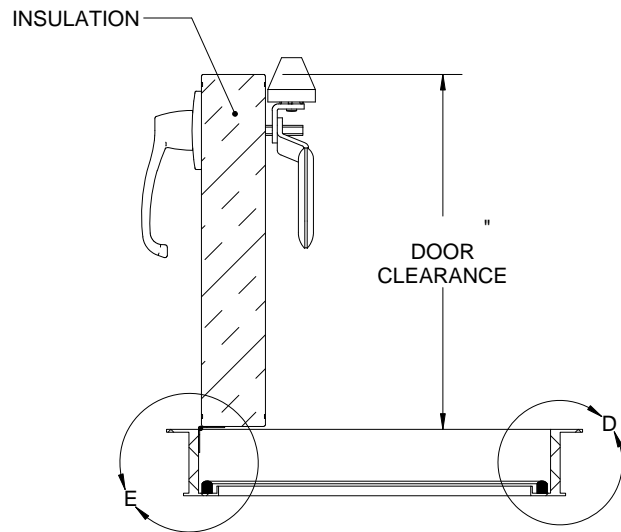
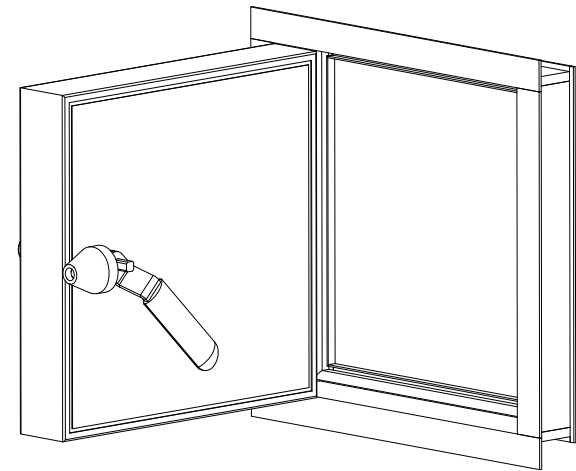
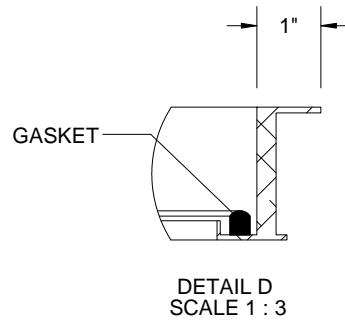
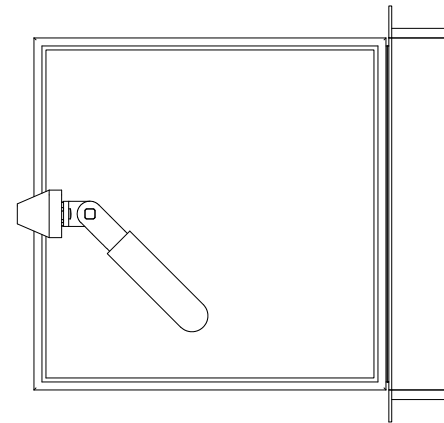
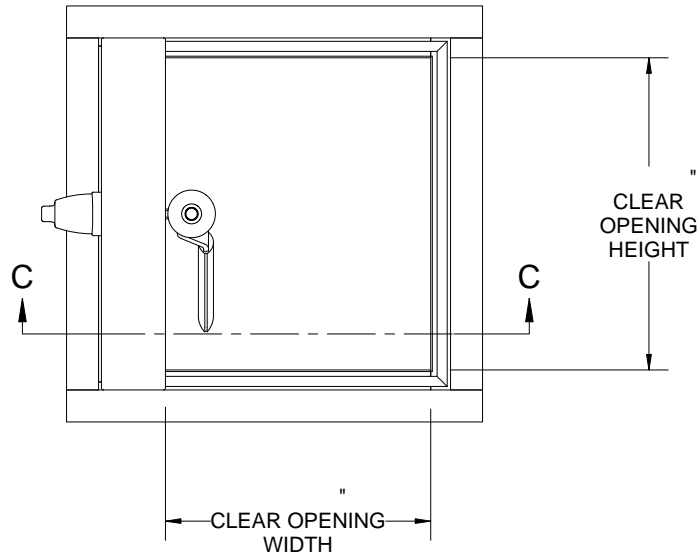

PART#:			TITLE:		
<b>nystrom</b>					
9300 73rd Avenue North, Minneapolis, MN 55428					
NAME	DATE	SIZE	DWG. NO.	REV	
DRAWN		A		A	
RELEASED			WEIGHT: 5.9	SHEET 2 OF 2	