



Coastal Zone Access Door

Model(s): XTL-H

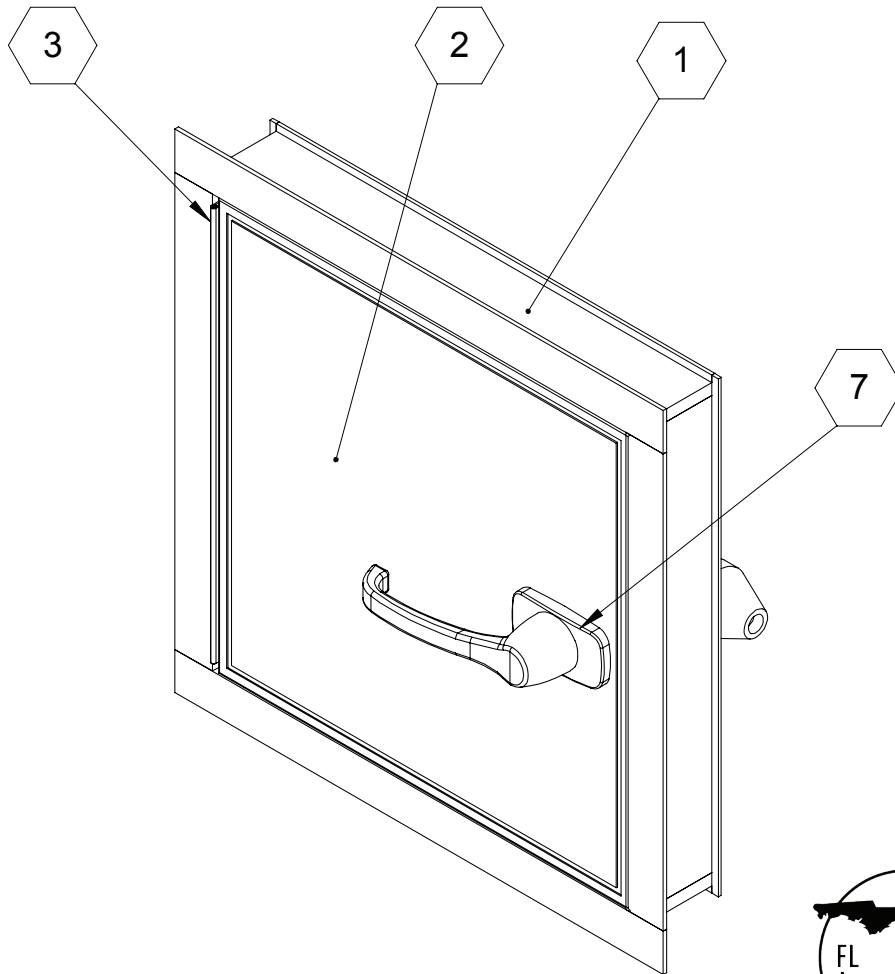

Table of Contents

General Description.....2
 Installation.....3
 Operation.....4
 Maintenance.....7
 Spare Parts List.....7
 Standard Warranty.....8
 Factory Assistance.....9

Copyright

2017 by Nystrom, Inc. All rights reserved.

This document contains proprietary information. No part of this document may be reproduced without the prior written consent of Nystrom, Inc.

Note

The information in this document is subject to change without notice.

General Safety Precautions

Improper selection, installation, or use can cause personal injury or property damage. It is solely the responsibility of the user, through its own analysis to select products suitable for their specific application requirements, ensure they are properly maintained, and limit their use to its intended purpose.

Follow proper local, state and federal regulations for proper installation and operation requirements.

GENERAL DESCRIPTION

Access Doors are designed and built for years of convenient and easy access to mechanical areas in commercial buildings.

The following is a general instruction for installing, operating and maintaining Access Doors. These are recommended general guidelines only. Locally accepted practices and procedures should be followed to ensure the ultimate durability of access doors installed into the various different types of construction.

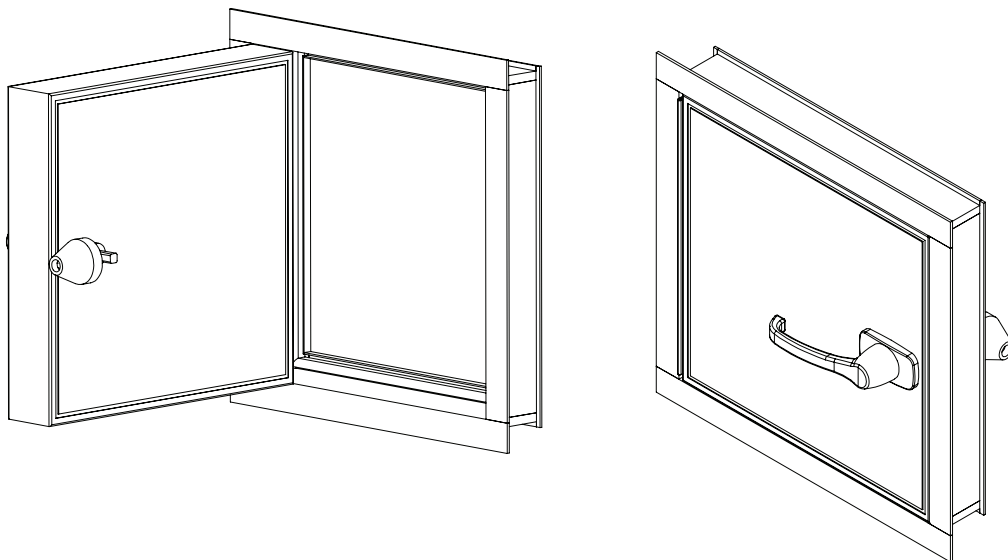

INSTALLATION

Proper installation is critical to maintaining and withstanding the design wind pressures shown on the product label.

1. Prior to inserting door into opening, check to see that opening is properly sized approximately 1/4 inch larger than door assembly. If the rough opening clearance exceeds 3/8 inch on any side, solid wood blocking must be provided.
2. Apply a bead of exterior grade sealant on exterior wall around perimeter of opening or exterior grade closed-cell foam tape under the trim flange of the door frame. Foam tape between 1/8 inch and 3/16 inch is recommended.
3. Place closed door assembly into opening. Center and square door in opening. Do not stretch, compress or rack frame.
4. Temporary shims may be used to help maintain the location and squareness of the door until it is secured in place. When shimming, the gap between frame and door should be equal at top, bottom, and side opposite hinge to ensure squareness of door.
5. Secure door frame to wall as follows:

Wood Substrates	#8 (0.164" dia.) X 2-1/4" Series 300 SS wood screws with minimum bending yield stress 90 ksi, and minimum 1-3/4" penetration.
Steel Substrates	#14 ITW Buildex, 304 stainless steel tappers, minimum 26 gage (.018") steel.
Masonry and Concrete Substrates	3/16" or 1/4" dia. ITW Buildex Tapcons, minimum 1" embedment.

1 Latch Doors

Width	Flange Width (A)	Fastener-Fastener Spacing (B)
12"	13-3/16"	4-3/8"
18"	19-3/16"	6-3/8"
22"	23-3/16"	7-3/4"
24"	25-3/16"	8-3/8"
36"	37-3/16"	12-3/8"

Height	Flange Height (C)	Fastener-Fastener Spacing (D)
12"	13-3/16"	4-3/8"
18"	19-3/16"	6-3/8"
24"	25-3/16"	8-3/8"

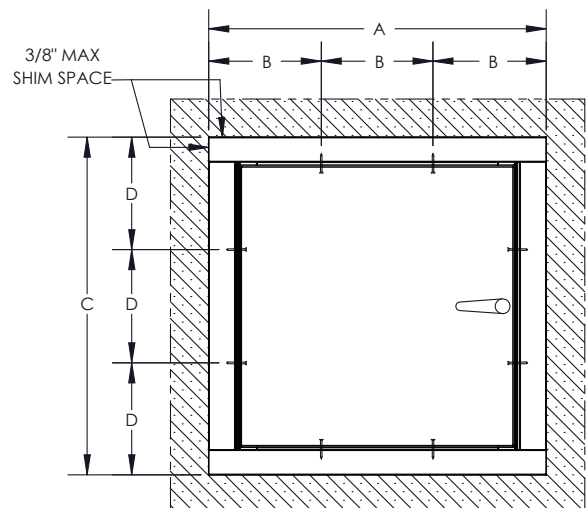

INSTALLATION

2 Latch Doors

Width	Flange Width (A)	Fastener-Fastener Spacing (B)
12"	13-3/16"	4-3/8"
18"	19-3/16"	6-3/8"
22"	23-3/16"	7-3/4"
24"	25-3/16"	8-3/8"
26"	37-3/16"	12-3/8"

Height	Flange Height (E)	Fastener-Fastener Spacing (F)	(G)
30"	31-3/16"	9"	8"
36"	37-3/16"	11"	10"
48"	49-3/16"	15"	14"

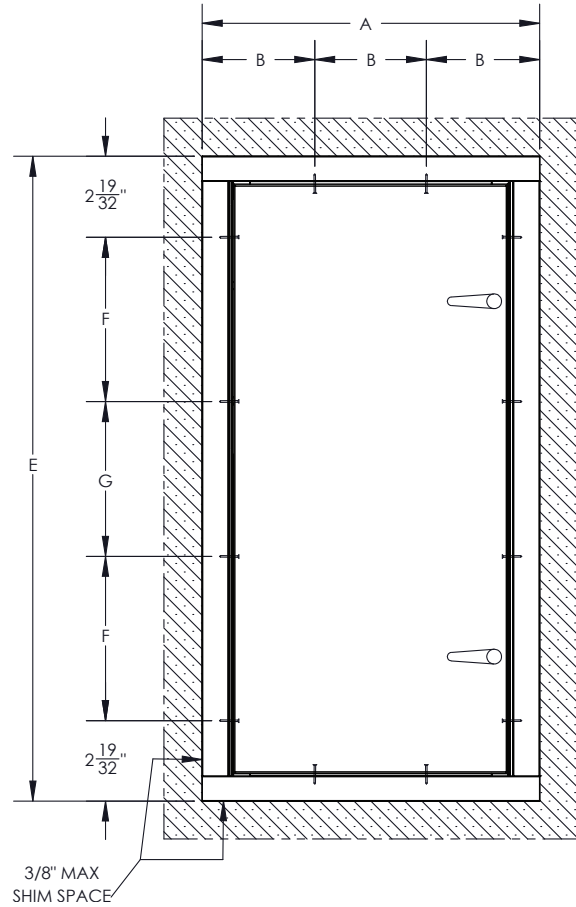

- Open and close the door to confirm that it operates freely. The screw heads should be snug against the frame, but must not be over-tightened to the point where the frame flexes or moves out of square. You may wish to apply sealant over the screw heads to reduce the possibility of air and water infiltration.
- Apply a bead of silicone type caulking around the inside perimeter of the frame to fill void between wall opening and door frame.
- Install handle(s).

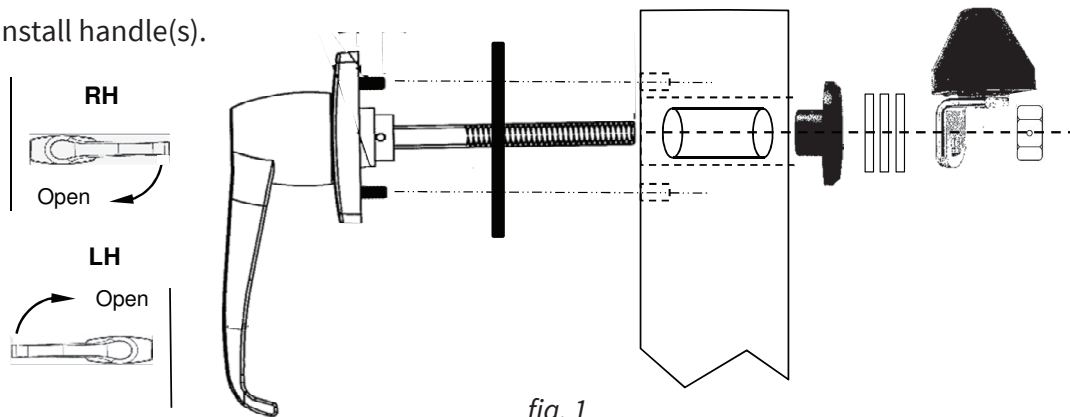

fig. 1

INSTALLATION

Tools Required

- 9/16 inch Open-End or Box Wrench
- Caulk Gun
- Rag or Paper Towel
- Tube of permanently-flexible sealant: 3M 400 UV Silicone or Red Devil Silicone Shield Kitchen & Bath

Handle Installation (fig. 1)

1. Insert the metal sleeve into the latch hole of the door panel. This sleeve will protect the foam core of the door panel from over-compression when the latch nut is tightened.
2. Insert the flat rubber gasket over the shaft, and the two mounting studs, of the latch housing.
3. Insert the latch shaft through the larger bore hole, aligning the two studs under the latch housing with the two smaller holes in the door panel. **Note: before proceeding with Step 4, verify that the latch is properly oriented for the desired handling.**
4. While holding the latch handle in place, use a permanently-flexible sealant to completely fill around the latch shaft inside the metal sleeve. This step is necessary in order to seal the latch from water leakage on exterior applications when the door is submitted to high wind loads. **Note: If your sealant is something other than the two recommended, be certain that it is permanently flexible so that it does not set up and impede operation of the latch.**
5. Insert the inside trim cap onto the latch shaft, embedding the narrow collar into the sealant.
6. Assemble additional components onto the latch shaft in the order shown in the illustration below.
 - a. The number of washers inserted between the inside trim cap and the roller cam bracket will affect the gasket compression of the closed/latched door, and therefore its ability to seal against air and water leakage. Two or three washers are typically required.
 - b. Start with three washers, then add the roller cam and install the flange nut tight. When the door is closed and the latch engaged, the outside surface of the door panel should be flush with the outside of the frame.
 - i. If the door panel seems loose or protrudes from the frame with the latch closed, remove one washer.
 - ii. If the latch draws the door panel more than 1/16 inch below the surface of the frame, add one washer.
 - c. Replace the flange nut with the Nylok nut. Tighten securely.
7. Clean off any excess sealant.

OPERATION

Access doors are designed and built for years of dependable wall access. Our access doors come standard with a paint grip finish.

MAINTENANCE

- Access doors should be manually operated once a year to check performance.
- Lubricate moving parts such as hinges and latches with a silicone spray lube as required to maintain a smooth opening and closing of the door. Do not over grease. Do not use regular lubricating oil as it can attract dust and grit.
- Non-moving parts can be cleaned with a mild soap or dish washing detergent and water solution.
- Gaskets can be cleaned with a clean, damp, lint-free cloth. Do not apply mineral oils, vinyl dressings, or other lubricants to the gasket as they can cause the gasket to break down over time.

STANDARD WARRANTY

Nystrom warrants all Access Doors to be free from manufacturing defects in materials, factory finishes and workmanship for a period of one (1) year from the date of shipment. Should a product fail to function in normal use within this period, Nystrom shall furnish a replacement or new part at Nystrom's discretion. Failure to use product in methods consistent with Nystrom product manuals shall relieve Nystrom of any liability. Our liability under this warranty excludes installation or removal costs involved in the product replacement and excludes any responsibility for incidental or consequential damage of any nature.

Customer Actions for Claims on Product During Warranty Period

1. Contact the Customer Service Department, Nystrom, Minneapolis, MN, Telephone: 800.547.2635, to obtain a Return Material Authorization (RMA) number.
2. You will be sent an "RMA" that is required to be filled out and returned with the shipment.
3. The following information must appear on the outside of the package:
 - RMA number marked on the outside of box
4. Return defective product FREIGHT PREPAID. Collect shipments will be refused.
5. The factory will not process warranty claims until the customer has properly accomplished the above items.
6. Nystrom may accept the entire claim; part or none of the claim if our inspection of the returned parts proves the failure was for reasons other than defective material or factory workmanship.

Important Notes

1. Nystrom will not be responsible for damage incurred during the return shipment.
2. All returns subject to inspection and a \$50 evaluation fee.
3. This RMA is not authorization for credit. Credits and/or replacements will be issued upon evaluation of returned product.
4. RMA is valid for thirty (30) days from issue date.

FACTORY ASSISTANCE

Nystrom engineers and manufactures access doors for worldwide customers. Our products enable safe access to mechanical equipment. Recognized as an industry leader, Nystrom has been relied upon by building and construction professions for over 50 years and we pride ourselves in offering exceptional technical support.

Please do not return any product before discussing your application problem with a Nystrom representative and obtaining a Return Authorization.

Your Nystrom representative is eager to help you. Please feel free to call your representative or contact Nystrom to discuss your application.

Nystrom
9300 73rd Avenue North
Minneapolis, MN 55428

Phone: 800.547.2635
Fax: 800.317.8770
Email: info@nystrom.com

Visit www.nystrom.com for the latest version of this document and more information.



9300 73rd Avenue North
Minneapolis, MN 55428

Phone (800) 547-2635
Fax (800) 317-8770

