

SEISMIC PAN FLOORING SYSTEM – BLOCKOUT APPLICATION

MODEL(S): EJM-FLP/FLPw

FLOOR TO FLOOR COVER SYSTEM – 18” through 24” SIZES ONLY

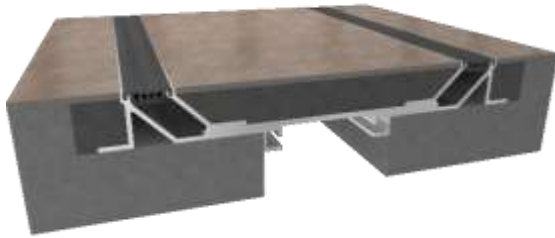

GENERAL DESCRIPTION

The Seismic Pan Flooring System is commonly used for stone, terrazzo tile and concrete slabs as well as most traditional flooring materials in courtyards and walkways. It's capable of accommodating lateral shear and multi-directional movement including

GENERAL SAFETY PRECAUTIONS Improper selection, installation, or use can cause personal injury or property damage. It is solely the responsibility of the user, through their own analysis, to select products suitable to the specific application requirements, ensure proper maintenance and use as intended. Follow local, state, and federal regulations for proper installation and operation requirements.

vertical displacement.

Introduction + Safety

Please read the complete instructions carefully before beginning any work. To ensure proper installation and performance of the product, the following actions must be completed by the installing contractor. Failure to do so will affect the product warranty.

Transportation + Storage

- Inspect all shipments and materials for missing or damaged components and hardware.
- Material must be stored in a clean, dry location.

Preparation

- Locate the packing slip(s) and/or shop drawings.
- Verify that all products listed on the packing slip are included in the package.
- Check the products for damage. If products are damaged, report a freight claim immediately and leave the products in their packaging. If you sign for products without reporting damage, you waive your right to a freight claim and will be responsible for replacement costs.
- Read the instructions thoroughly before beginning installation.

Tool List

- Tape measure
- Phillips screwdriver
- Vinyl tile roller
- Drivers for anchors
- Levels
- Denatured alcohol & clean rags
- Duct tape
- Rubber mallet
- Wooden block
- Trowel
- Chop saw to cut product to length
- Drill with 3/16” masonry bit
- Broom & dustpan or vacuum

Included with the expansion joint system

- Ø1/4” x 2-1/4” HH Tapcon (#32088)
- Ø1/4” x 2-1/4” FH Tapcon (#32089)
- Ø1/4” x 1.0” Self-Tapping Screw (#30032) for butt-splice connectors

Pre-Installation

1. Pour slabs with blockouts as shown on shop drawings. Note: Blockout width changes with System size.
2. Ensure the area where the expansion joint system is being installed (including the blockout area) is smooth and level. High spots should be ground down and low spots filled in. Make sure the substrate is clean by sweeping and/or vacuuming the substrate.



Aluminum Pan		
Model #	Part #	"W" Dimension
EJN-FLP-1800	32072	40.25
EJN-FLP-2000	32073	42.25
EJN-FLP-2200	32074	44.25
EJN-FLP-2400	32075	46.25

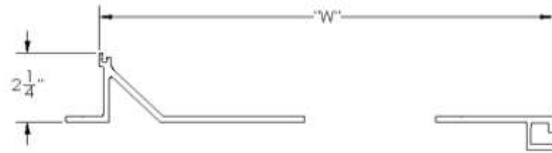

Aluminum Edge Frame		
Model #	Part #	"W" Dimension
EJN-FLP-1800/2000/2200/2400	32048	13.82"

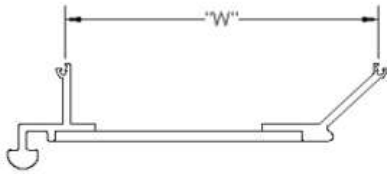

Aluminum Pan		
Model #	Part #	"W" Dimension
EJN-FLP-1800W	32084	27.25"
EJN-FLP-2000W	32085	29.25"
EJN-FLP-2200W	32086	31.25"
EJN-FLP-2400W	32087	33.25"

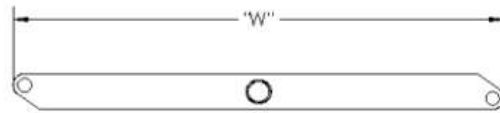

Seismic Centering Bar		
Model #	Part #	"W" Dimension
EJN-FLP-1800/2000	WBAR30-KIT-FLP	31.13"
EJN-FLP-2200/2400	WBAR36-KIT-FLP	37.13"

INSTALLATION (EJN-FLP-1800 through EJN-FLP-2400 ONLY)

1. After determining that the area is smooth and level, the installer shall inspect opposing concrete slabs, corners and blockouts for acceptability. For repair (if required) refer to

Pre-Installation Step #2. Also, measure joint opening for proper size as called for on shop drawings and for specific blockout information. **See Figure #1**

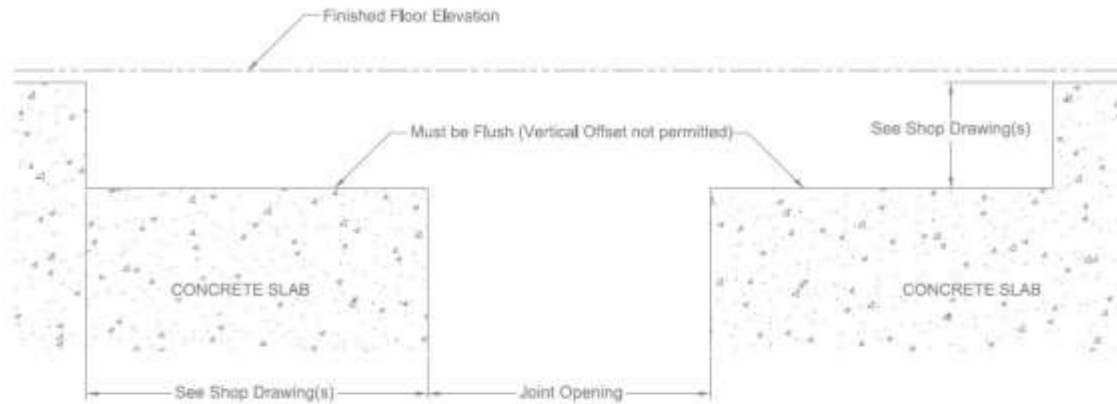

Figure #1

2. On each of the Aluminum Base Members find the “V score marks” to pre-locate the holes you need to drill. After pre-drilling the $\text{Ø}3/16$ ” holes in the Aluminum Edge Frames per the Shop Drawings, position them in the blockouts as shown below. Using the frame as a template, mark and drill $\text{Ø}3/16$ holes in the blockout for the $\text{Ø}1/4$ ” Tapcon anchors using the “V score marks to locate”. Set the Aluminum Bases into position and attach with supplied $\text{Ø}1/4$ ” Tapcons through the previously drilled holes as shown on the Shop Drawings. (Note: stagger seams on opposite sides of the joint opening – See Step #8 before proceeding.) Be sure and place the Aluminum Edge Frames (#32048) 4” (102mm) apart as shown below. **See Figure #2**

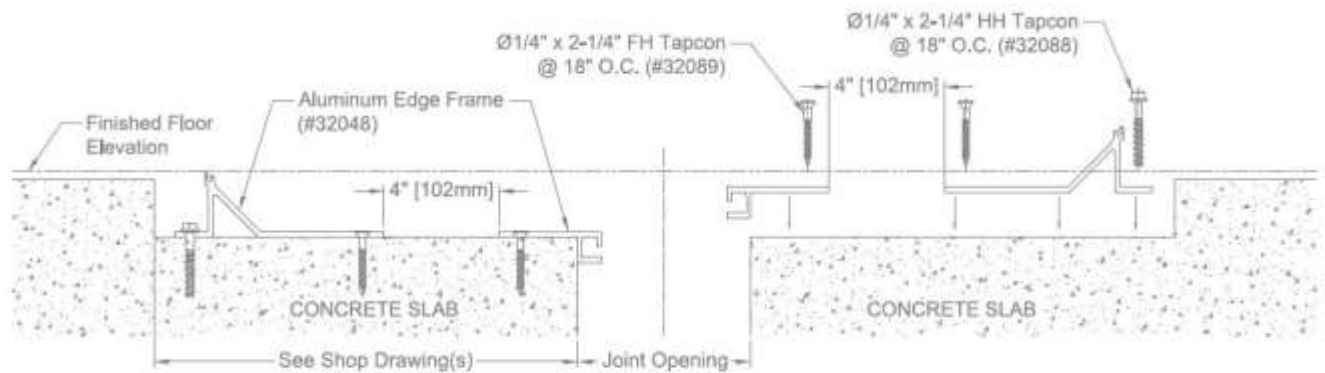

Figure #2

3. Remove the $\text{Ø}3/8$ ” Hex Head Bolts from each centering bar mechanism but DO NOT DISCARD – will be used in Step #7. Insert Centering Bar Mechanisms into cavities in Aluminum Edge Frames. Space bars at 18” O.C. **See Figure #3 & 3a.**

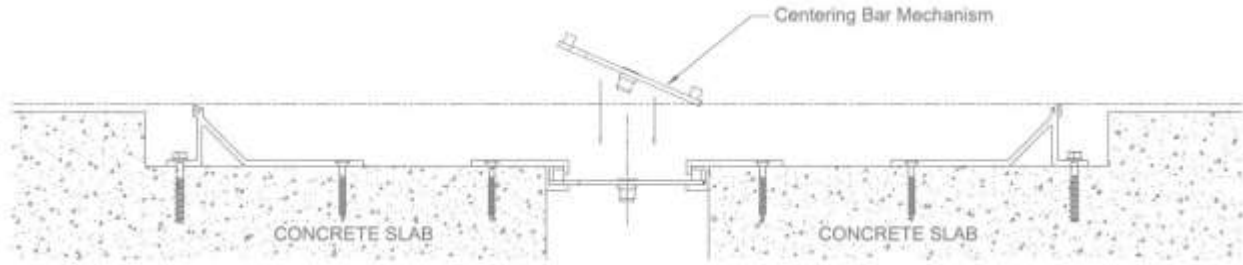
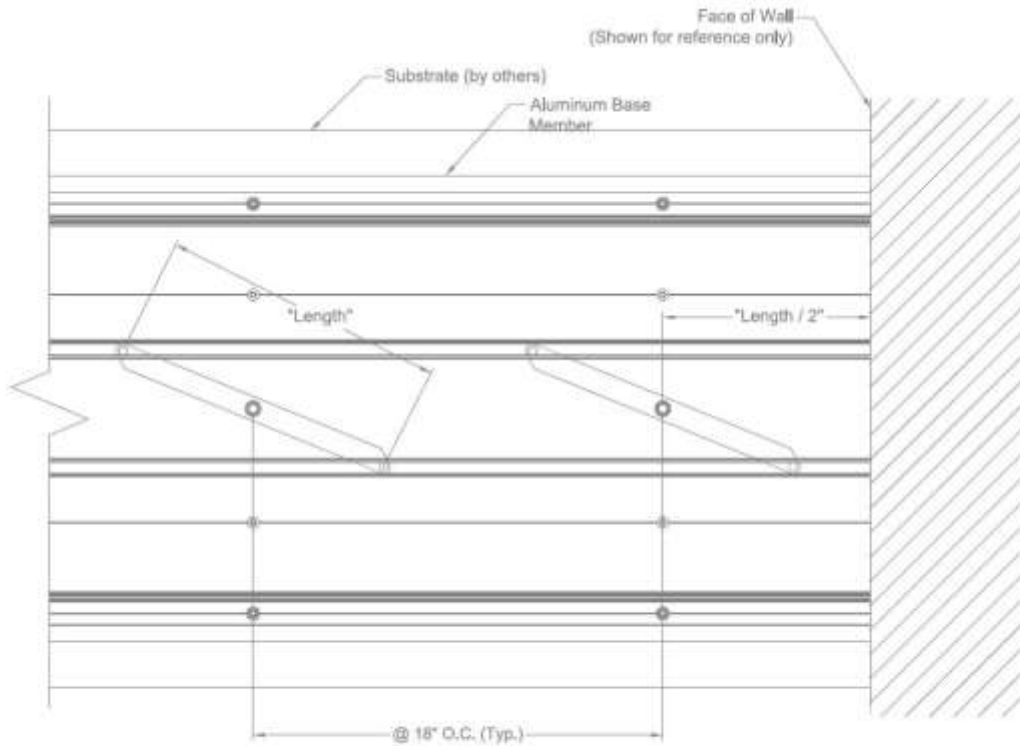

Figure #3



All centering bar mechanisms have to be oriented the same direction, Note: Flat part of bar should face into Joint Opening area.

Figure #3a

4. After aluminum bases are installed, start adding Centering Bar Mechanisms and butt splice connections to one end of each aluminum pan. This can be done outside of the blockout / joint opening. Using the Butt Splice Connector (#32179) as a template, locate as shown in Figure #4. From the top, mark and drill the two Ø3/16” holes at one end of

each pan. When assembling in block out, use $\text{Ø}1/4$ " screws provided (#30032) as shown below. Connectors should be placed in the inside bottom of the pan at one end – one per pan assembly. **See Figure #4.**

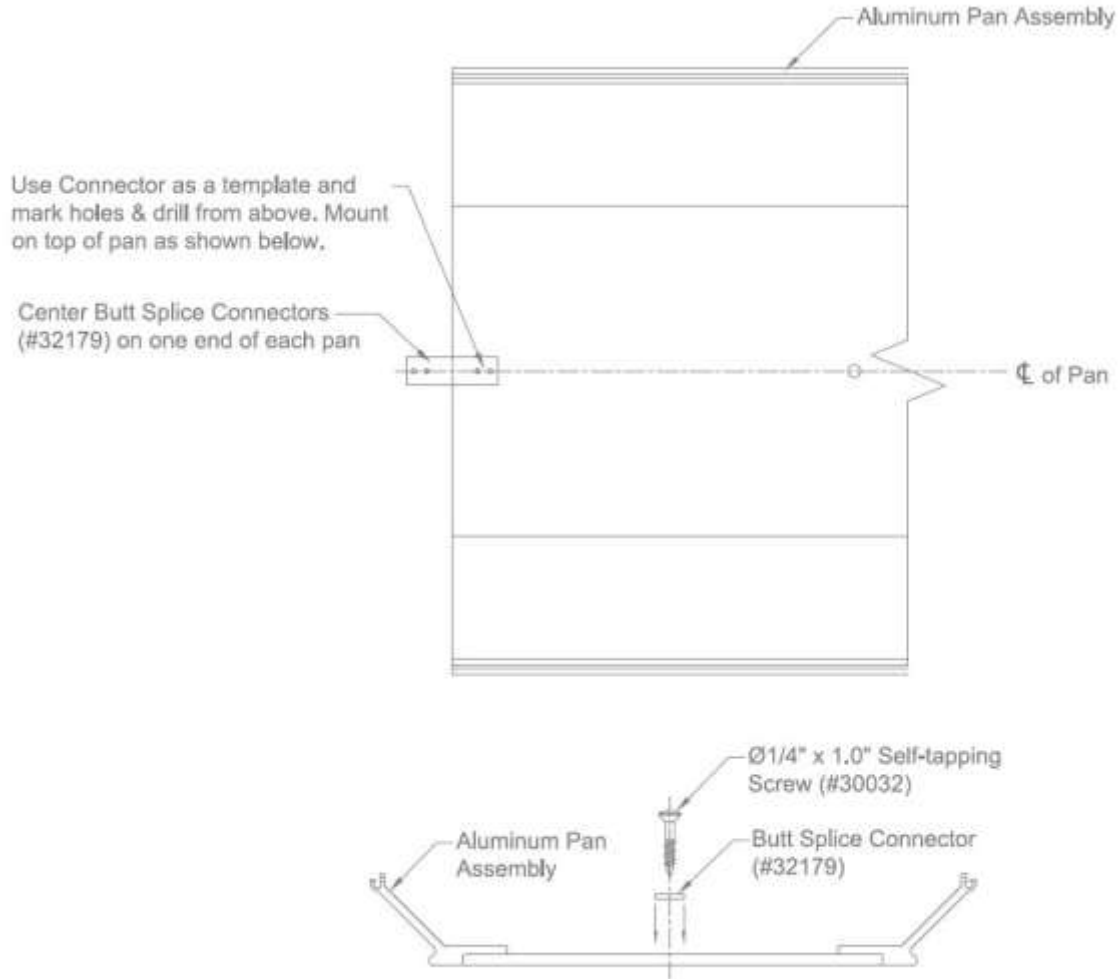

Figure #4

5. Take measurement “X” of aluminum pan and align first centering bar to this dimension as shown. This step will aid you in locating the Centering Bar Mechanisms under the aluminum pan in future steps. **See Figure #5.**
6. Center the Aluminum Pan Assembly over the joint opening while keeping the end of pan snug with wall / reference line as shown in Figure #5. Use a Phillips head screwdriver (or similar) to properly align the holes in the centering bar mechanisms with the pre-drilled holes in the Aluminum Pan Assembly. **See Figure #6.**

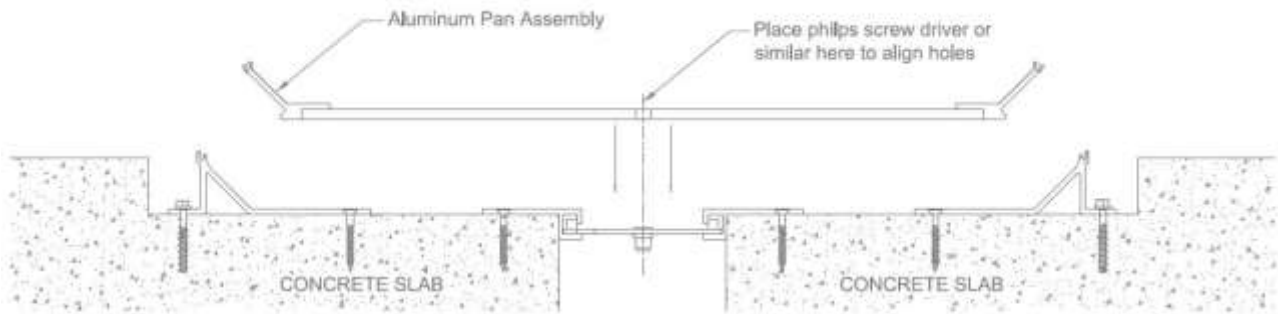

Figure #6

- Using the $\text{Ø}3/8$ " Hex Head bolts shipped with the centering bar mechanisms but removed in Step #3, insert the bolts through the aluminum pans and into the centering bar mechanisms. Make sure to not overtighten – centering bars must move freely. Cover bolt heads with plastic caps (#32094) before adding infill. **See Figure #7.**

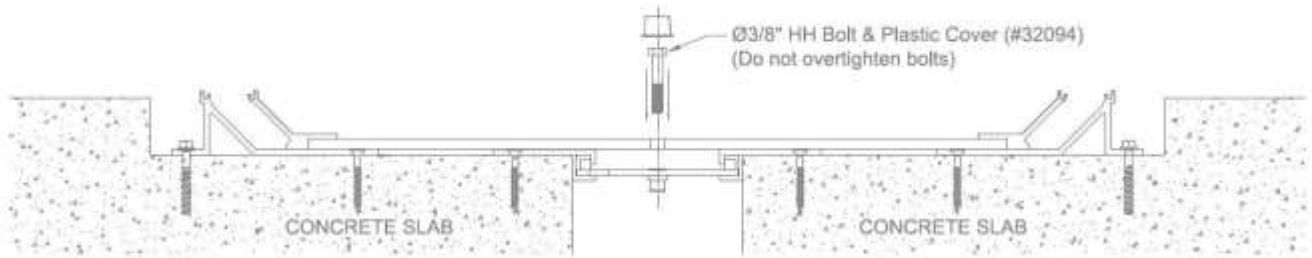

Figure #7

- Repeat Steps #4 through #7 to align centering bar mechanisms for the next section of aluminum pan. Be sure to start threading centering bars for this section (do not completely tighten centering bars per Step #7). Ensure aluminum pan sections butt tightly together and that the outside edges align from section to section. Once all the Aluminum Pans are butted tightly together and all butt splice connectors are installed, inspect all $\text{Ø}3/8$ " Hex Head Bolts to confirm the centering bars spin freely. **See Figure #8.**

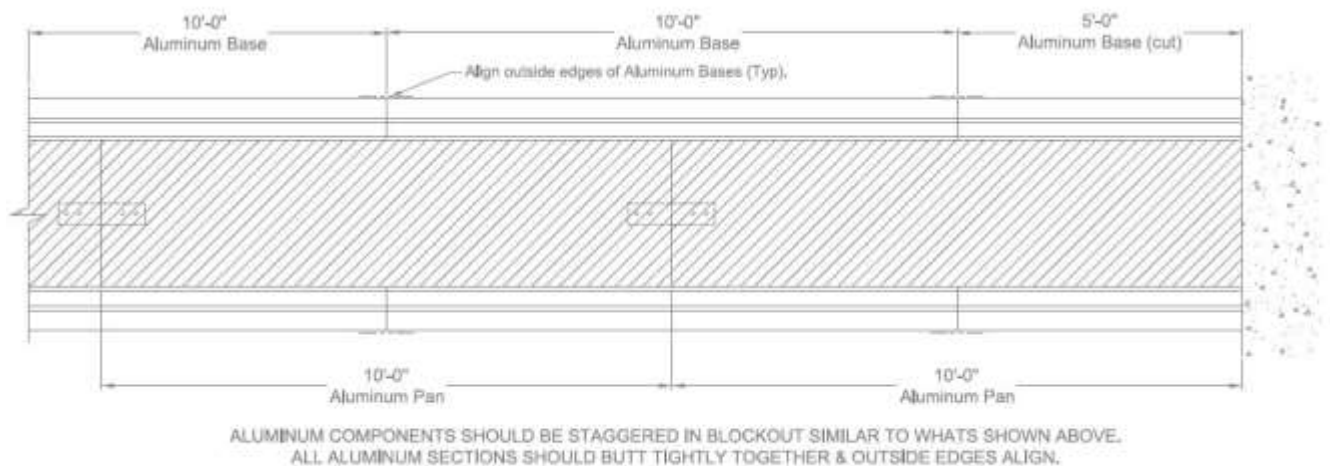

Figure #8

9. Use Duct Tape or similar heavy tape continuously on each side of the EJ System to protect joint opening through the next final steps. **See Figure #9.**

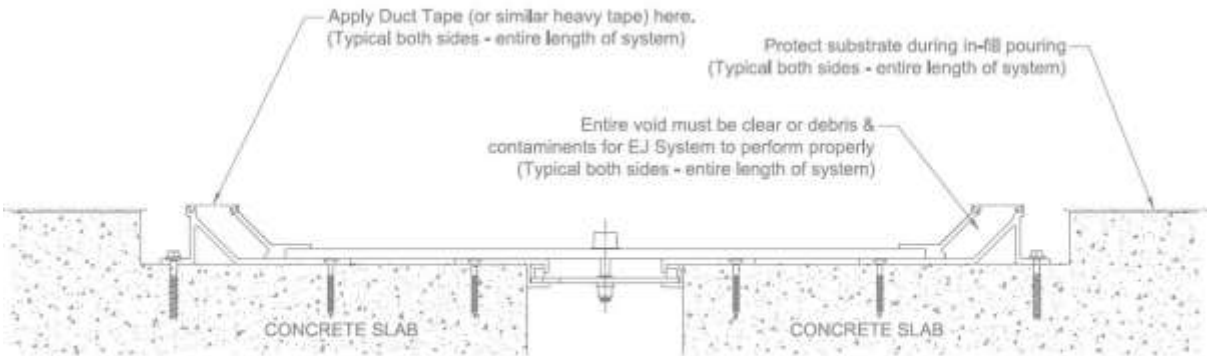

Figure #9

10. Before mixing the infill, material care should be taken to remove all dust and debris from the blockout areas and inside the aluminum pan. All surfaces must be clean and dry prior to installing infill. Pour infill material into blockout voids and pan cavity. **Warning! Leave required recess for floor finish, finish material thickness, and proper placement.* **See Figure #10.**

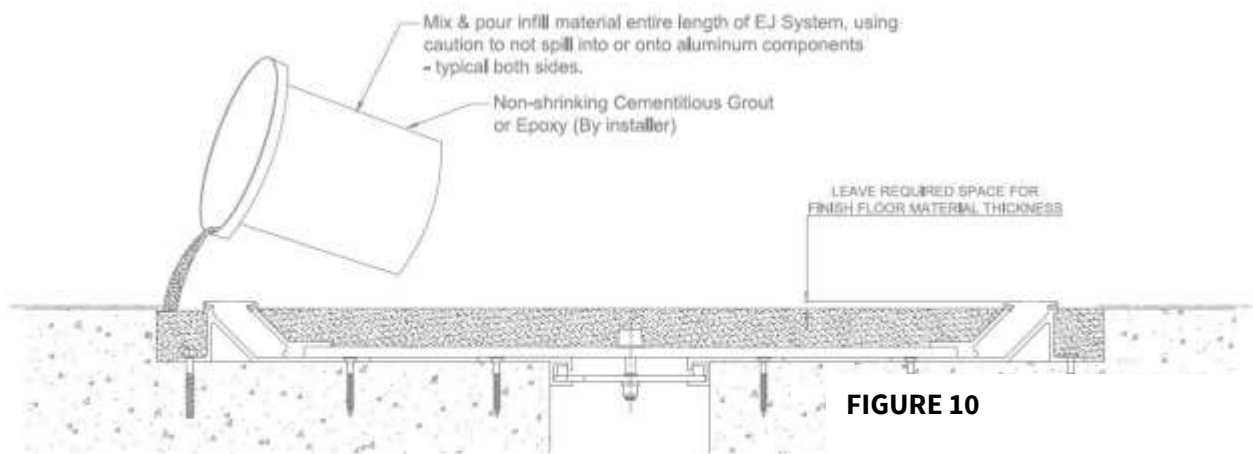

Figure #10

11. Install finished floor material. Be sure to follow the manufacturer's instructions. Joint opening should remain protected throughout this process. **See Figure #11.**

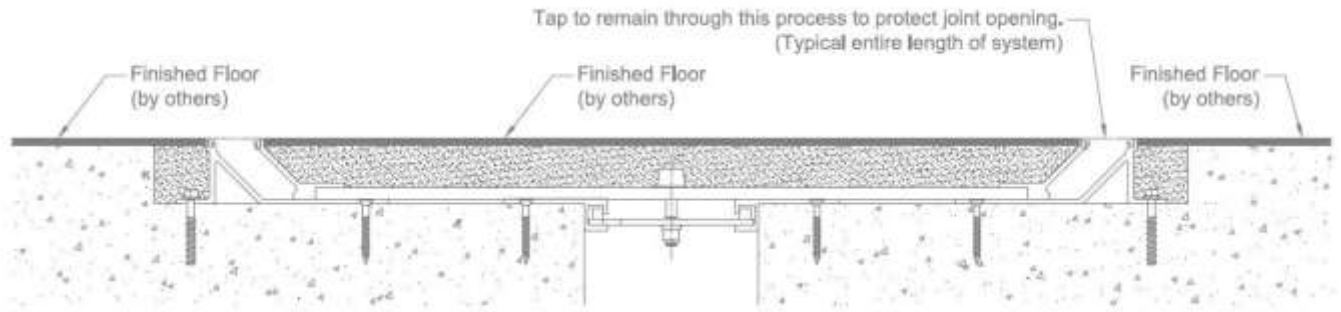

Figure #11

12. Remove heavy tape from joint opening. Install elastomeric seals. Use a vinyl tile roller or similar, to ensure seal tabs completely lock into cavities in aluminum components. Use care not to mark or tear seal. Final seal seams should be offset from all other aluminum seams. Clean off seals using denatured alcohol and a clean rag when complete to remove any construction dust or debris. **See Figure #12.**

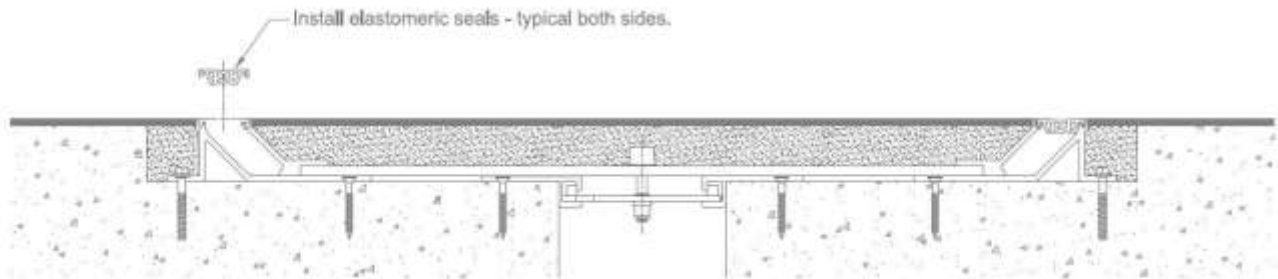
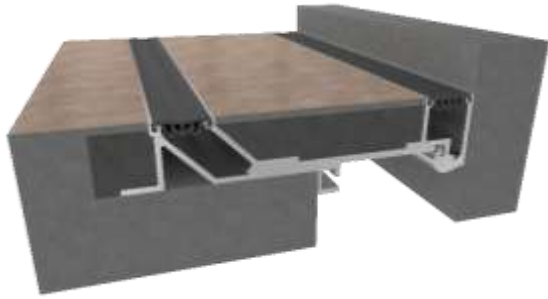

Figure #12

FLOOR TO WALL COVER SYSTEM – 18” through 24” SIZES ONLY



GENERAL DESCRIPTION

Nystrom Seismic Flooring Pan System is designed to match the EJN-FLP system in corner applications.

Pre-Installation

1. Pour slabs with blockouts as shown on shop drawings.
2. Ensure the area where the expansion joint system is being installed (including the blockout area) is smooth and level. High spots should be ground down and low spots filled in. Make sure the substrate is clean by sweeping and/or vacuuming the substrate.

INSTALLATION

3. After determining that the area is smooth and level, the installer shall inspect opposing concrete slabs, corners and blockouts for acceptability. For repair (if required) refer to Pre-Installation Step #2, also, measure joint opening for proper size as called for on shop drawings and for specific blockout information. **See Figure #13.**

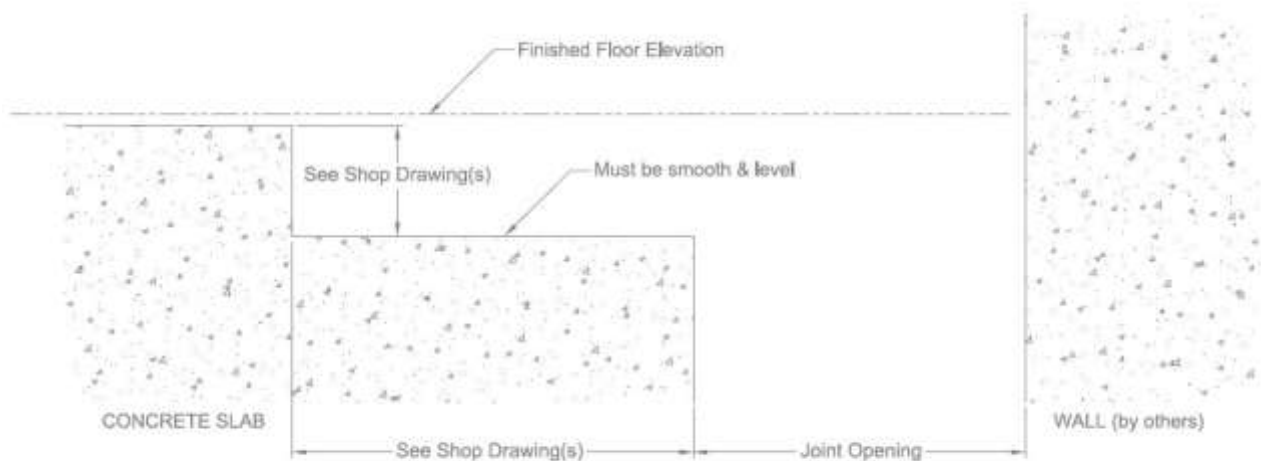
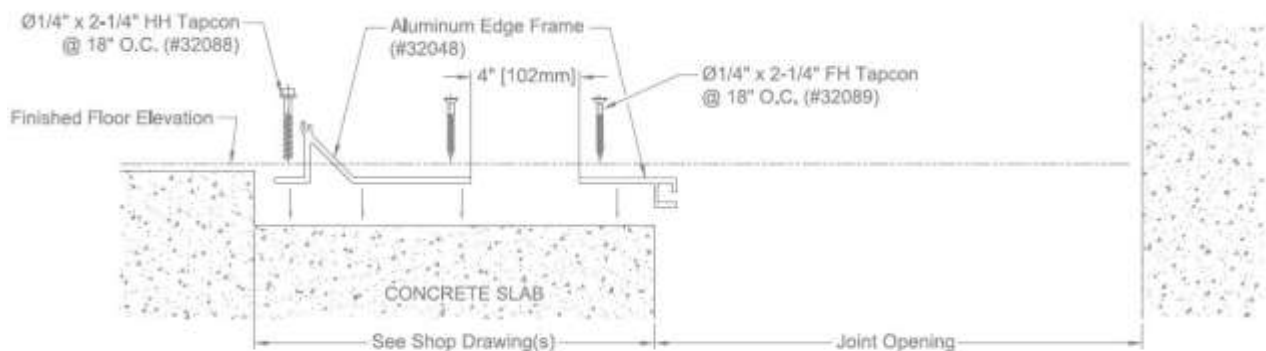
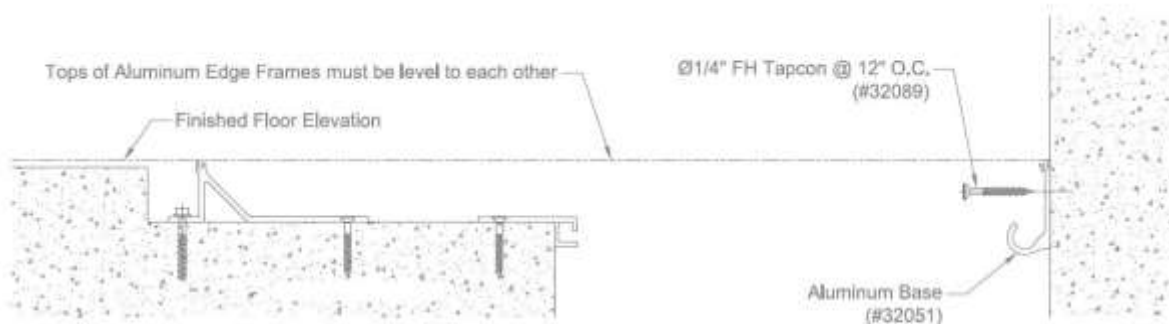

Figure #13

13. On each of the Aluminum Base Members find the “V score marks” to pre-locate the holes you need to drill. After pre-drilling the $\text{Ø}3/16$ ” holes in the Aluminum Bases per the Shop Drawings, position them in the blockout as shown below. Using the frame as a template, mark, and drill $\text{Ø}3/16$ holes in the blockout for the $\text{Ø}1/4$ ” Tapcon anchors using the “V score marks” to locate. Set the Aluminum Bases into position and attach with supplied $\text{Ø}1/4$ ” Tapcons through the previously drilled holes as shown on the Shop Drawings. (Note: stagger seams the entire length of the joint opening – See Step #17 before proceeding.) Be sure and place the Aluminum Edges Frames (#32048) 4” (102mm) apart as show below. **See Figure #14.**



14. In preparation for fastening wall mount extrusion (#32051) pre-drill $\text{Ø}3/16$ ” holes as shown on the Shop Drawings – use the “V score mark” to properly locate the holes. Hold extrusion against wall and make sure that it is level with the adjacent aluminum edge frame assembly. Snap a chalk line to insure level installation. Use a 5-foot piece wall mount at start of each joint run. Fasten wall mounted aluminum base with $\text{Ø}1/4$ ” FH Tapcons utilizing the field pre-drilled holes as a template. **See Figure #15.**



15. After aluminum bases are installed, start adding butt splice connections to one end of each aluminum pan. Using the Butt Splice Connector as a template, locate as shown in Figure #16. From the top, mark and drill the two $\text{Ø}3/16$ " holes at one end of each pan. When assembling in block out, use $\text{Ø}1/4$ " screws provided (#30032) as shown below. Connectors should be placed in the inside bottom of the pan at one end – one per pan assembly. **See Figure #16.**

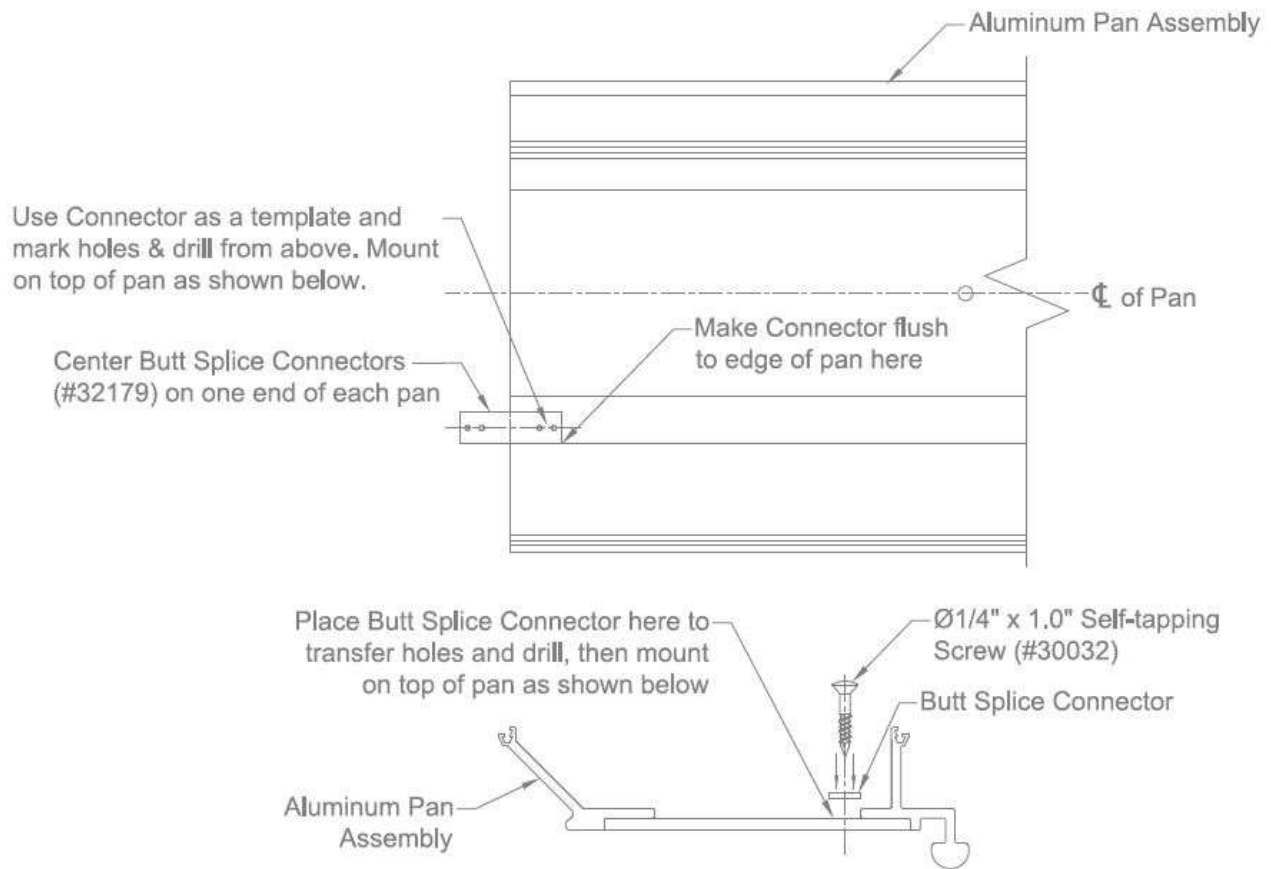

Figure #16

16. Gently set aluminum pans into place as shown above. **See Figure #17.**

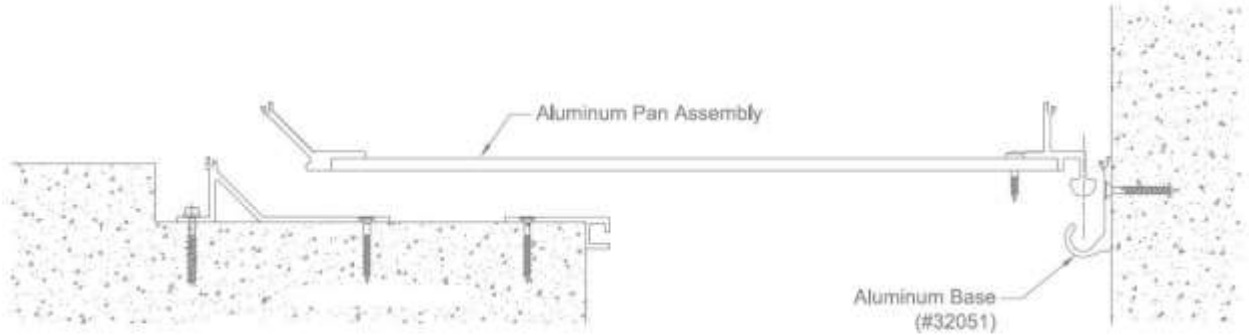

Figure #17

17. Repeat Steps #13 through #16 to align all sections of aluminum pans and aluminum bases. Ensure aluminum pan sections butt tightly together and that the outside edges align from section to section. Confirm all the Aluminum Pans are butted tightly together, and all butt splice connectors are installed properly. **See Figure #18.**

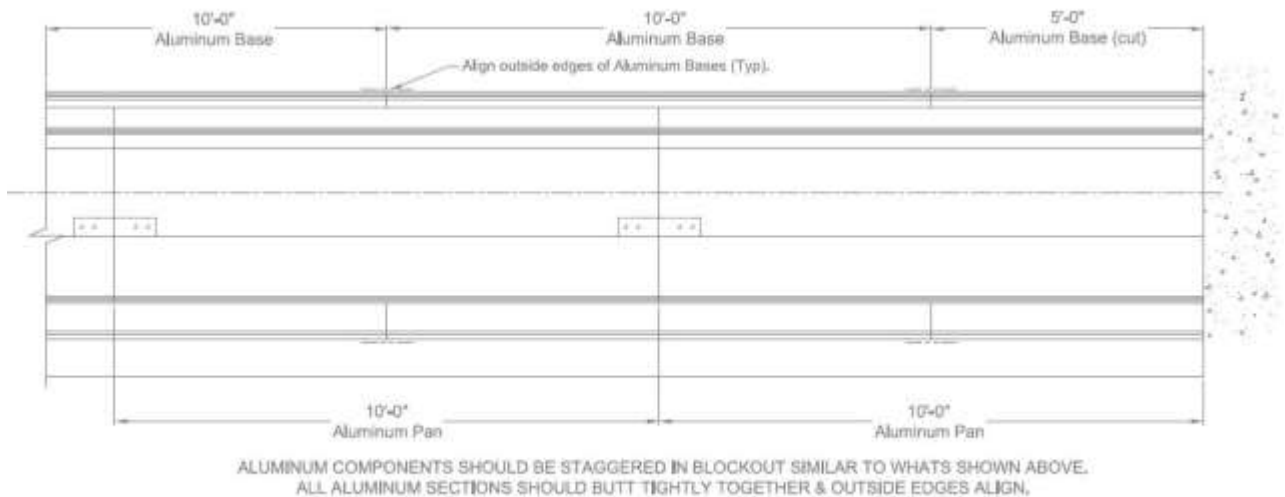

Figure #18

18. Use Duct Tape or similar heavy tape continuously on each side of the EJ System to protect joint opening through the next final steps. **See Figure #19.**

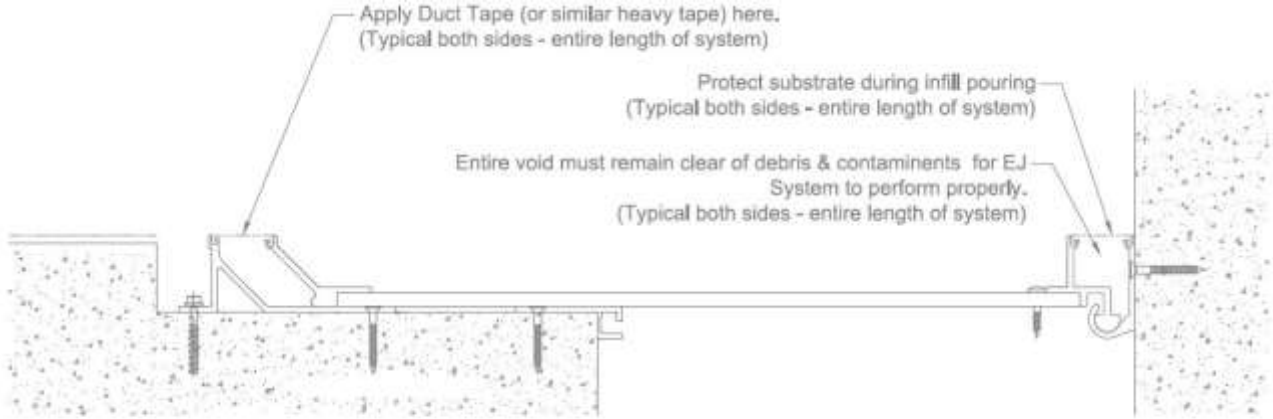

Figure #19

19. Before mixing the infill, material care should be taken to remove all dust and debris from the blockout areas and inside the aluminum pan. All surfaces must be clean and dry prior to installing infill. Pour infill material into blockout voids and pan cavity. *Warning! Leave required recess for floor finish, finish material thickness, and proper placement. **See Figure #20.**

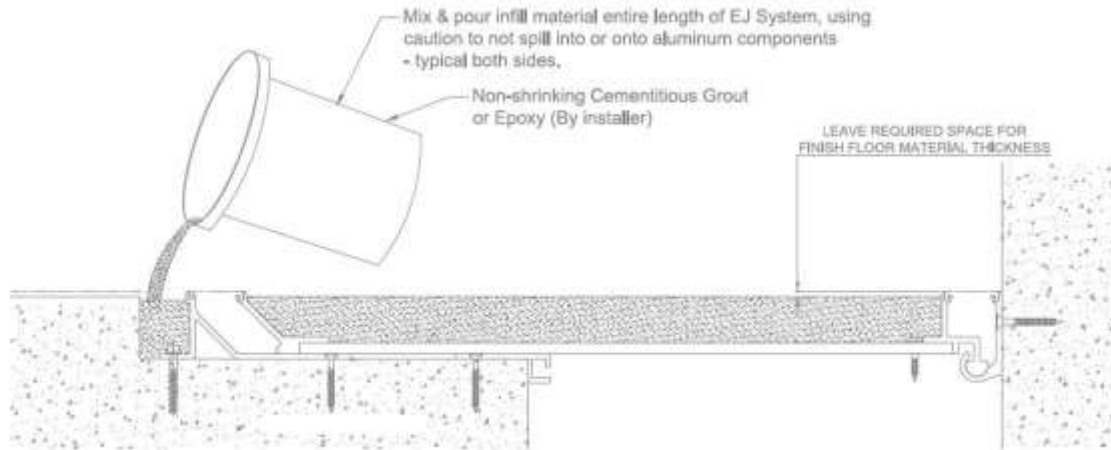

Figure #20

20. Install finished floor material. Be sure to follow the manufacturer's instructions. Joint opening should remain protected throughout this process. **See Figure #21.**



Figure #21

21. Remove heavy tape from joint opening. Install elastomeric seals. Use a vinyl tile roller or similar to ensure seal tabs completely lock into cavities in aluminum components. Use

care not to mark or tear seal. Final seal seams should be offset from all other aluminum seams. Clean off seals using denatured alcohol and a clean rag when complete to remove any construction dust or debris. **See Figure #22.**

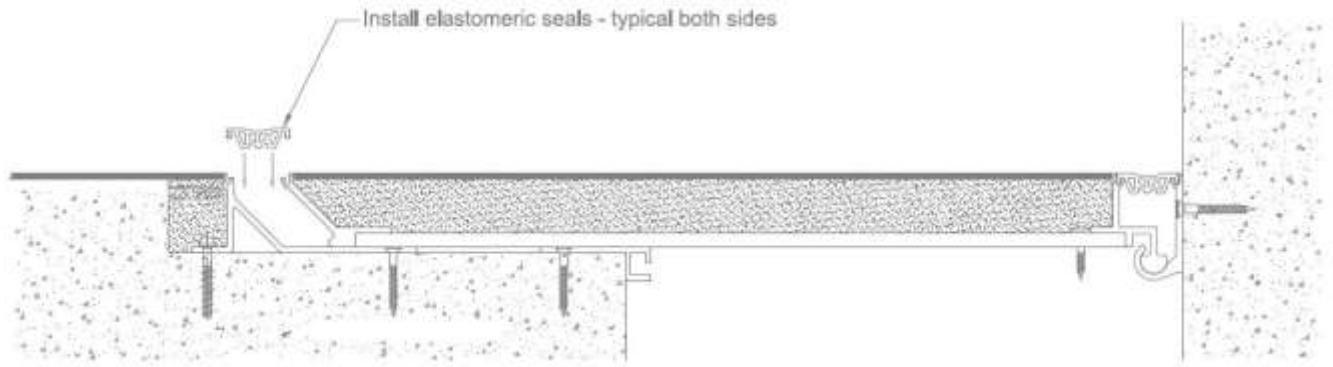

Figure #22

OPERATION

Expansion Joints are designed and built for years of dependable service.

MAINTENANCE

Perform annual inspections to make sure the system is still in position; all fasteners are tight and in place and there is no impedance of joint cover movement. Repair and/or replace as needed.

QUESTIONS?

For more information on installation, repair or replacement, please contact Customer & Sales Support at 800-547-2635 or visit nystrom.com