

# SEISMIC PAN FLOORING SYSTEM – BLOCKOUT APPLICATION

**MODEL(S): EJM-FLP/FLPw**

## FLOOR TO FLOOR COVER SYSTEM – 4” through 16” SIZES ONLY

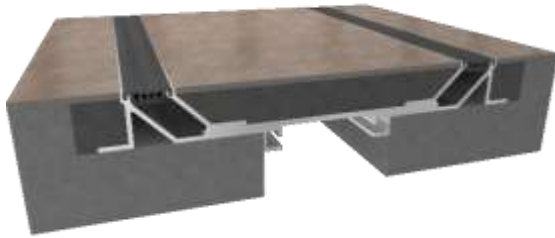

### GENERAL DESCRIPTION

The Seismic Pan Flooring System is commonly used for stone, terrazzo tile and concrete slabs as well as most traditional flooring materials in courtyards and walkways. It's capable of accommodating lateral shear and multi-directional movement including

**GENERAL SAFETY PRECAUTIONS** Improper selection, installation, or use can cause personal injury or property damage. It is solely the responsibility of the user, through their own analysis, to select products suitable to the specific application requirements, ensure proper maintenance and use as intended. Follow local, state, and federal regulations for proper installation and operation requirements.

vertical displacement.

### Introduction + Safety

Please read the complete instructions carefully before beginning any work. To ensure proper installation and performance of the product, the following actions must be completed by the installing contractor. Failure to do so will affect the product warranty.

### Transportation + Storage

- Inspect all shipments and materials for missing or damaged components and hardware.
- Material must be stored in a clean, dry location.

## Preparation

- Locate the packing slip(s) and/or shop drawings.
- Verify that all products listed on the packing slip are included in the package.
- Check the products for damage. If products are damaged, report a freight claim immediately and leave the products in their packaging. If you sign for products without reporting damage, you waive your right to a freight claim and will be responsible for replacement costs.
- Read the instructions thoroughly before beginning installation.

## Tool List

- Tape measure
- Phillips screwdriver
- Vinyl tile roller
- Drivers for anchors
- Levels
- Denatured alcohol & clean rags
- Duct tape
- Rubber mallet
- Wooden block
- Trowel
- Chop saw to cut product to length
- Drill with 3/16” masonry bit
- Broom & dustpan or vacuum

## Included with the expansion joint system

- Ø1/4” x 2-1/4” HH Tapcon (#32088)
- Ø1/4” x 2-1/4” FH Tapcon (#32089)
- Ø1/4” x 1.0” Self-Tapping Screw (#30032) for butt-splice connectors

## Pre-Installation

1. Pour slabs with blockouts as shown on shop drawings. Note: Blockout width changes with System size.
2. Ensure the area where the expansion joint system is being installed (including the blockout area) is smooth and level. High spots should be ground down and low spots filled in. Make sure the substrate is clean by sweeping and/or vacuuming the substrate.



Aluminum Pan		
Model #	Part #	"W" Dimension
EJN-FLP-400	32065	11.25"
EJN-FLP-600	32066	13.25"
EJN-FLP-800	32067	18.25"
EJN-FLP-1000	32068	20.25"
EJN-FLP-1200	32069	27.25"
EJN-FLP-1400	32070	29.25"
EJN-FLP-1600	32071	31.25"

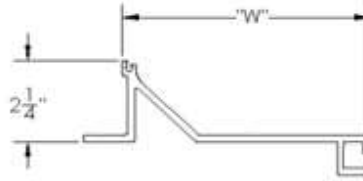

Aluminum Edge Frame		
Model #	Part #	"W" Dimension
EJN-FLP-400/600	32045	6.32"
EJN-FLP-800/1000	32046	7.82"
EJN-FLP-1200/1400/1600	32047	10.32"



Aluminum Pan		
Model #	Part #	"W" Dimension
EJN-FLP-400W	32077	6.44"
EJN-FLP-600W	32078	7.75"
EJN-FLP-800W	32079	11.25"
EJN-FLP-1000W	32080	13.25"
EJN-FLP-1200W	32081	17.75"
EJN-FLP-1400W	32082	19.75"
EJN-FLP-1600W	32083	21.75"

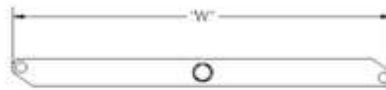

Seismic Centering Bar		
Model #	Part #	"W" Dimension
EJN-FLP-400	WBAR6-KIT-FLP	7.13"
EJN-FLP-600/800	WBAR12-KIT-FLP	13.13"
EJN-FLP-1000/1200	WBAR18-KIT-FLP	19.13"
EJN-FLP-1400/1600	WBAR24-KIT-FLP	25.13"

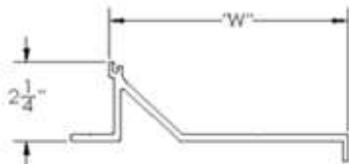

Aluminum Edge Frame		
Model #	Part #	"W" Dimension
EJN-FLP-200W/400W	32044	6.3125"

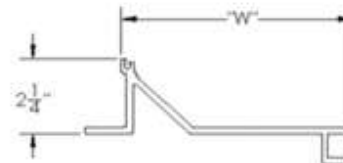

Aluminum Edge Frame		
Model #	Part #	"W" Dimension
EJN-FLP-600W	32045	6.32"
EJN-FLP-800W/1000W	32046	7.82"
EJN-FLP-1200W/1400W/1600W	32047	10.32"

## INSTALLATION (EJN-FLP-400 through EJN-FLP-1600 ONLY)

1. After determining that the area is smooth and level, the installer shall inspect opposing concrete slabs, corners and blockouts for acceptability. For repair (if required) refer to Pre-Installation Step #2. Also, measure joint opening for proper size as called for on shop drawings and for specific blockout information. **See Figure #1**

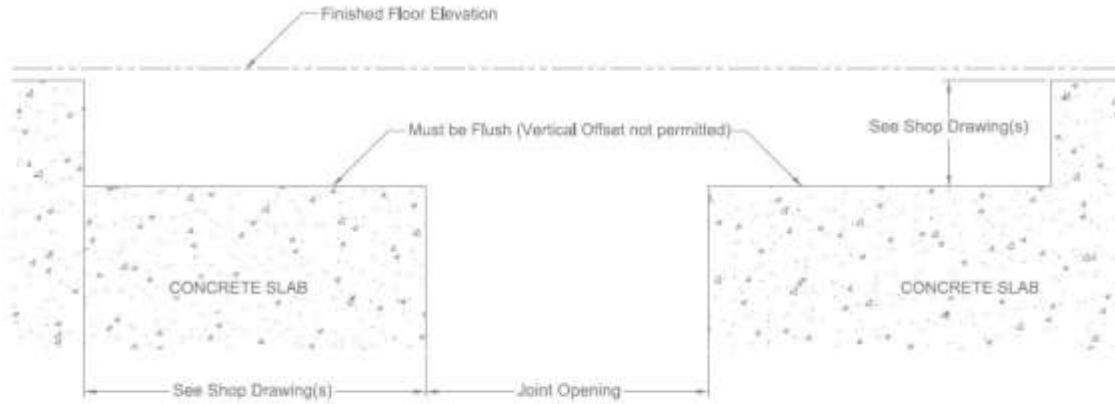

Figure #1

2. On each of the Aluminum Base Members find the “V score marks” to pre-locate the holes you need to drill. After pre-drilling the  $\text{Ø}3/16$ ” holes in the Aluminum Bases per the Shop Drawings, position them in the blockouts as shown below. Using the frame as a template, mark and drill  $\text{Ø}3/16$  holes in the blockout for the  $\text{Ø}1/4$ ” Tapcon anchors using the “V score marks to locate”. Set the Aluminum Bases into position and attach with supplied  $\text{Ø}1/4$ ” Tapcons through the previously drilled holes as shown on the Shop Drawings. (Note: stagger seams on opposite sides of the joint opening – See Step #8 before proceeding.) **See Figure #2**

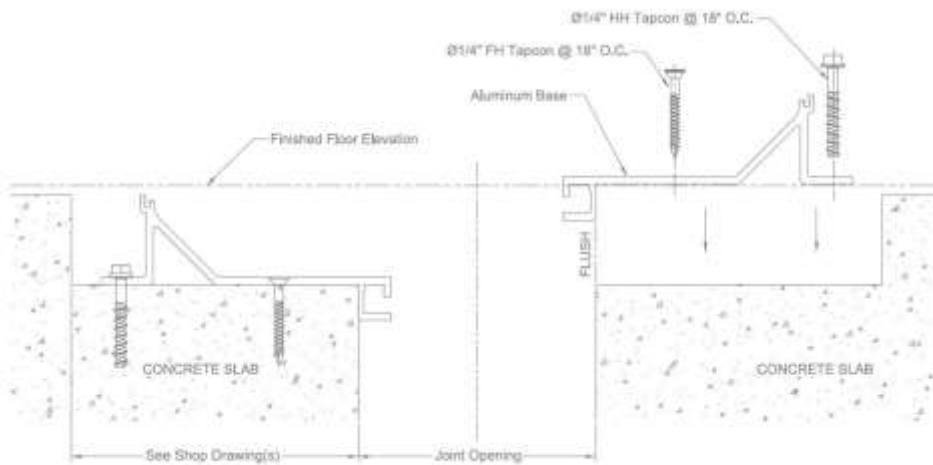

Figure #2

3. Remove the  $\text{Ø}3/8$ " Hex Head Bolts from each centering bar mechanism but DO NOT DISCARD – will be used in Step #7. Insert Centering Bar Mechanisms into cavities in Aluminum Bases. Space bars at 18" O.C. **See Figure #3 & 3a.**

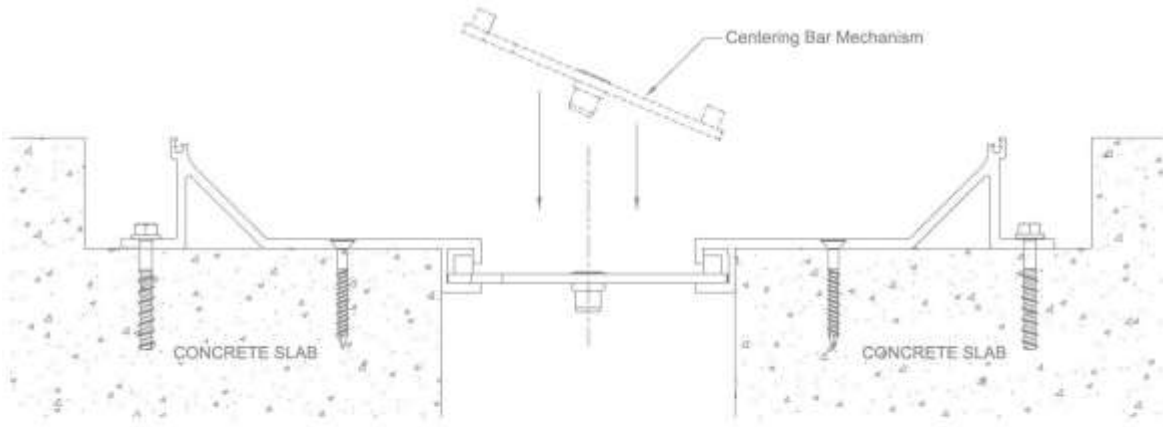
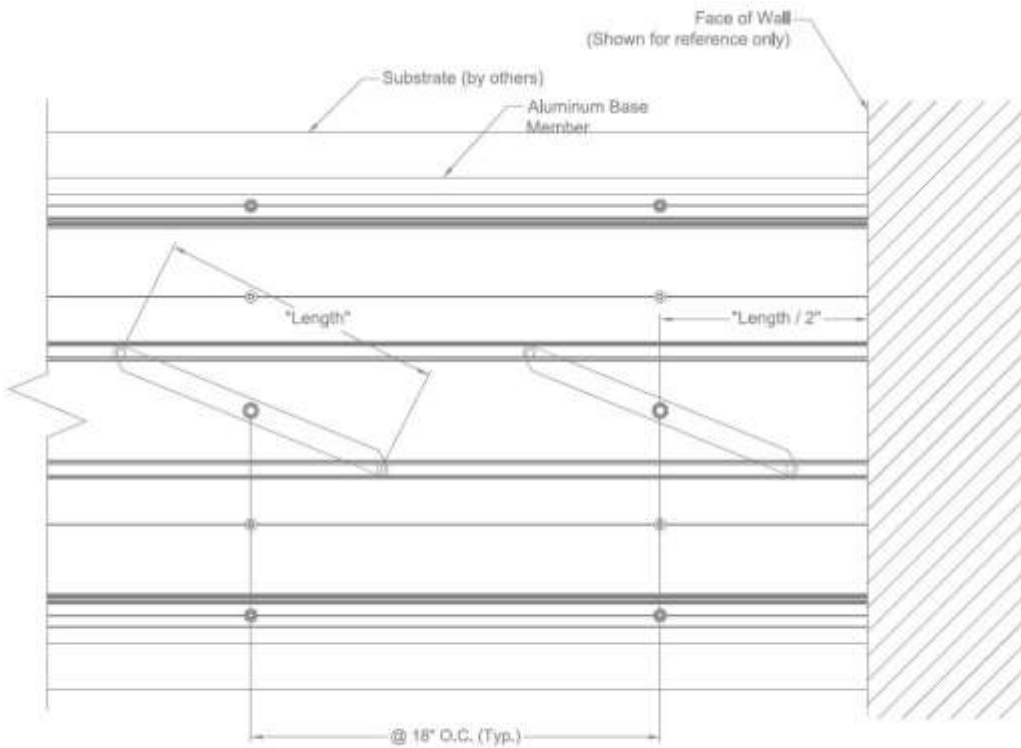

Figure #3



All centering bar mechanisms have to be oriented the same direction. Note: Flat part of bar should face into Joint Opening area.

Figure #3a

4. After aluminum bases are installed, start adding Centering Bar Mechanisms and butt splice connections to one end of each aluminum pan. This can be done outside of the blockout / joint opening. Using the Butt Splice Connector (#32179) as a template, locate as shown in Figure #4. From the top, mark and drill the two  $\text{Ø}3/16$ " holes at one end of each pan. When assembling in block out, use  $\text{Ø}1/4$ " screws provided (#30032) as shown below. Connectors should be placed in the inside bottom of the pan at one end – one per pan assembly. **See Figure #4.**

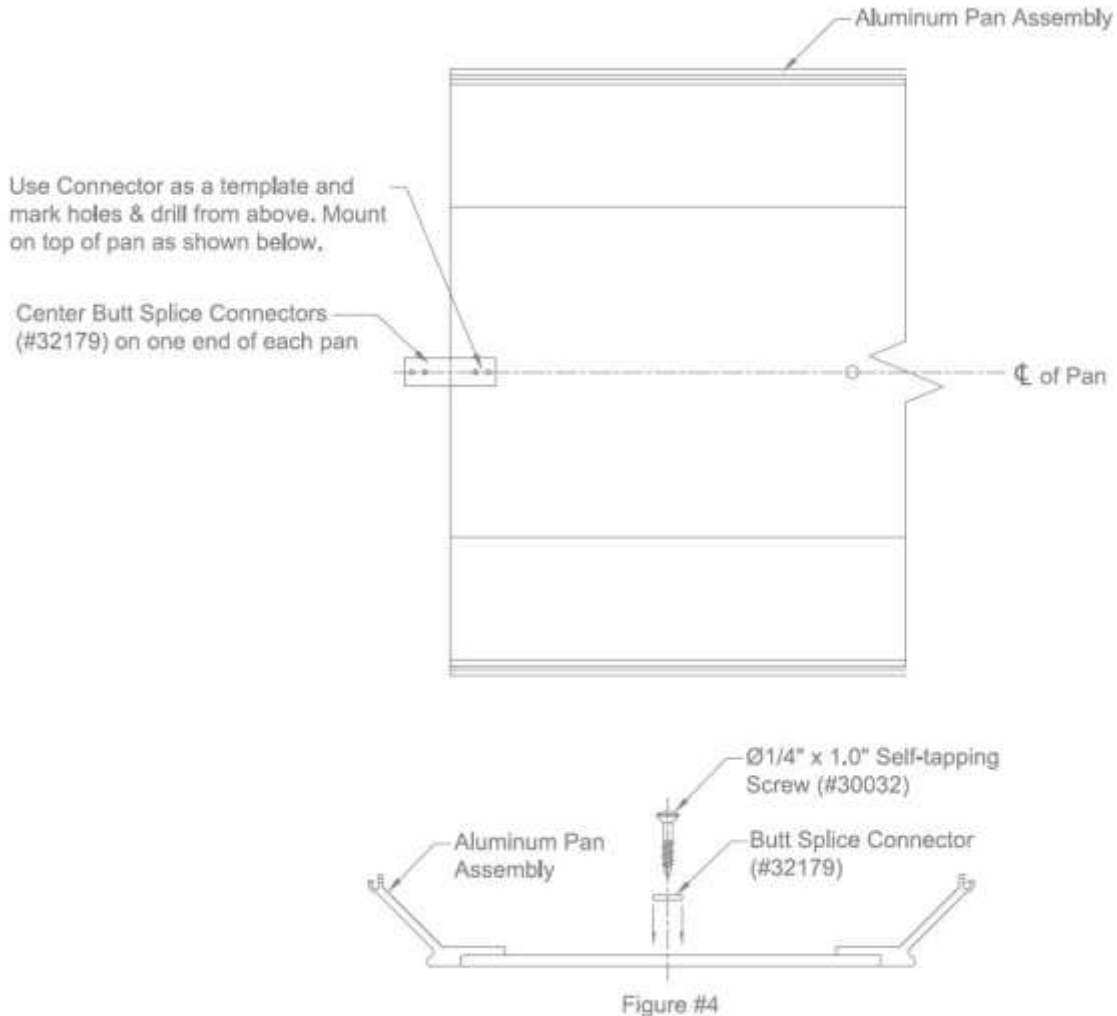

5. Take measurement "X" of aluminum pan and align first centering bar to this dimension as shown. This step will aid you in locating the Centering Bar Mechanisms under the aluminum pan in future steps. **See Figure #5.**

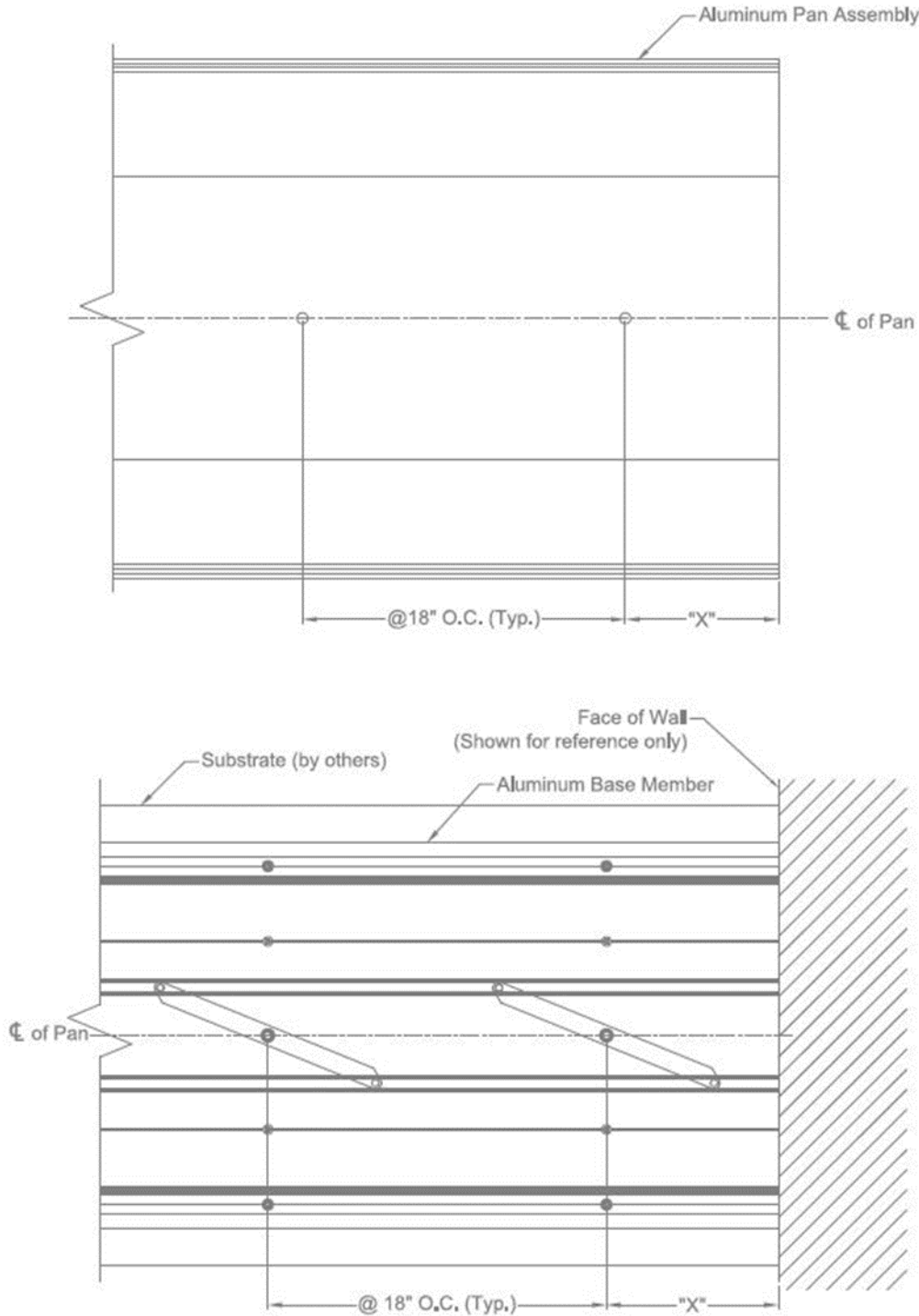

Figure #5

- Center the Aluminum Pan Assembly over the joint opening while keeping the end of pan snug with wall / reference line as shown in Figure #5. Use a Phillips head screwdriver (or similar) to properly align the holes in the centering bar mechanisms with the pre-drilled holes in the Aluminum Pan Assembly. **See Figure #6.**

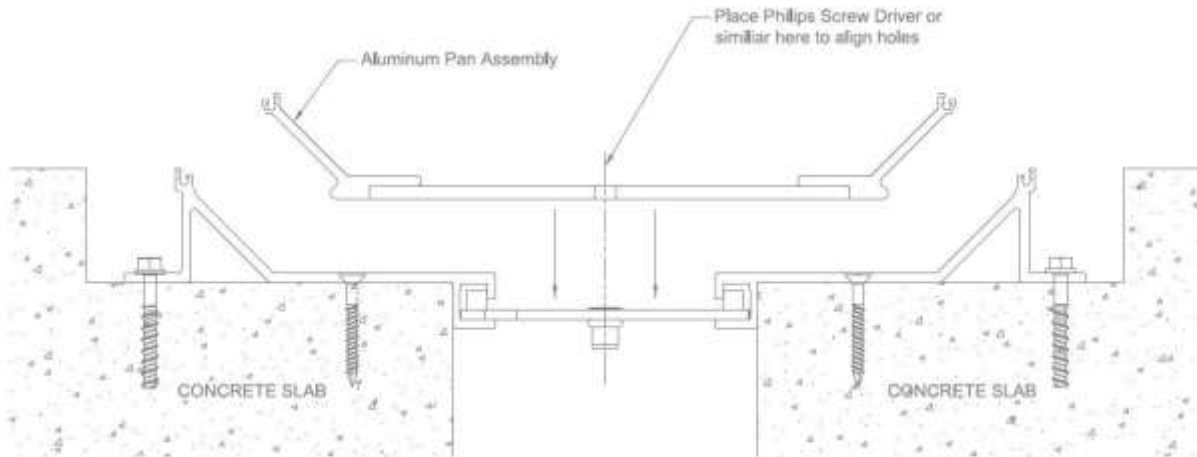

Figure #6

- Using the  $\text{Ø}3/8$ " Hex Head bolts shipped with the centering bar mechanisms but removed in Step #3, insert the bolts through the aluminum pans and into the centering bar mechanisms. Make sure to not overtighten – centering bars must move freely. Cover bolt heads with plastic caps (#32094) before adding infill. **See Figure #7.**

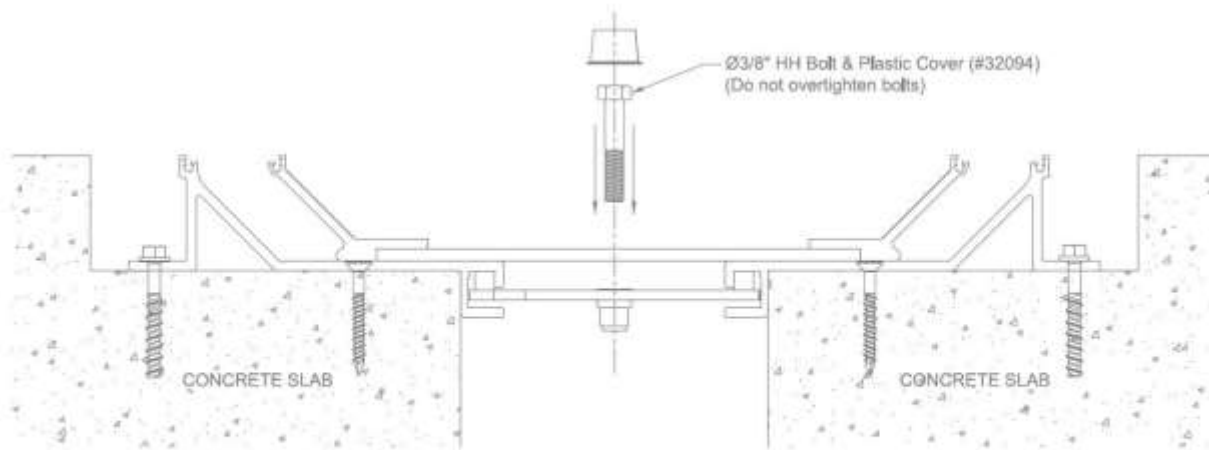

Figure #7

- Repeat Step #4 through 7 to align centering bar mechanisms for the next section of aluminum pan. Be sure to start threading centering bars for this section (do not completely tighten centering bars per Step #7). Ensure aluminum pan sections butt tightly together and that the outside edges align from section to section. Once all the



Aluminum Pans are butted tightly together and all butt splice connectors are installed, inspect all Ø3/8” Hex Head Bolts to confirm the centering bars spin freely. **See Figure #8.**

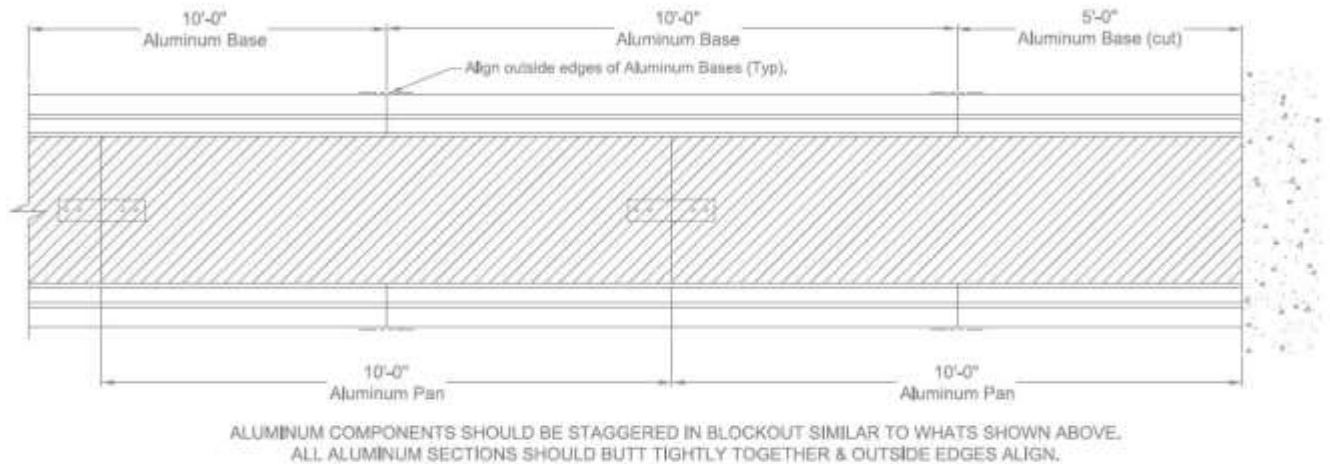

Figure #8

9. Use Duct Tape or similar heavy tape continuously on each side of the EJ System to protect joint opening through the next final steps. **See Figure #9.**

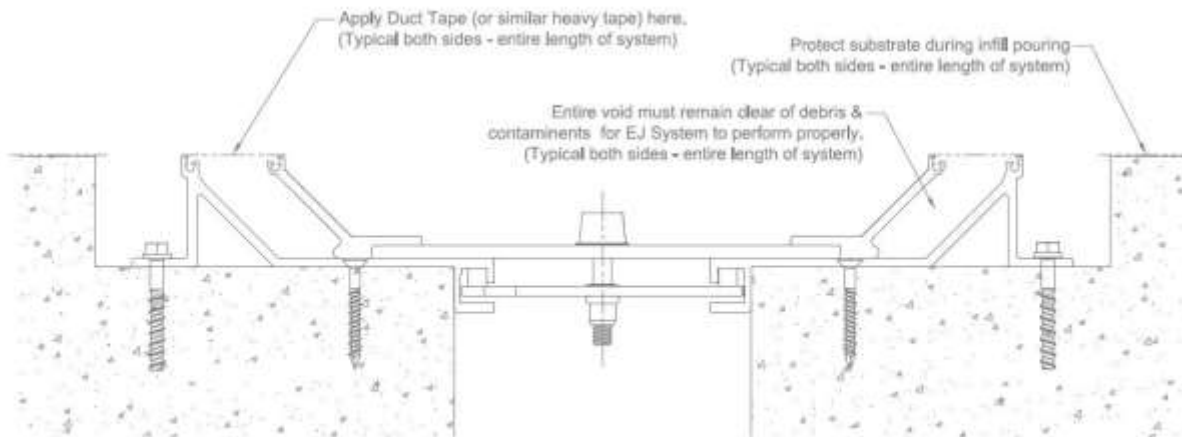

Figure #9

10. Before mixing the infill, material care should be taken to remove all dust and debris from the blockout areas and inside the aluminum pan. All surfaces must be clean and dry prior to installing infill. Pour infill material into blockout voids and pan cavity. *\*Warning! Leave required recess for floor finish, finish material thickness, and proper placement.* **See Figure #10.**

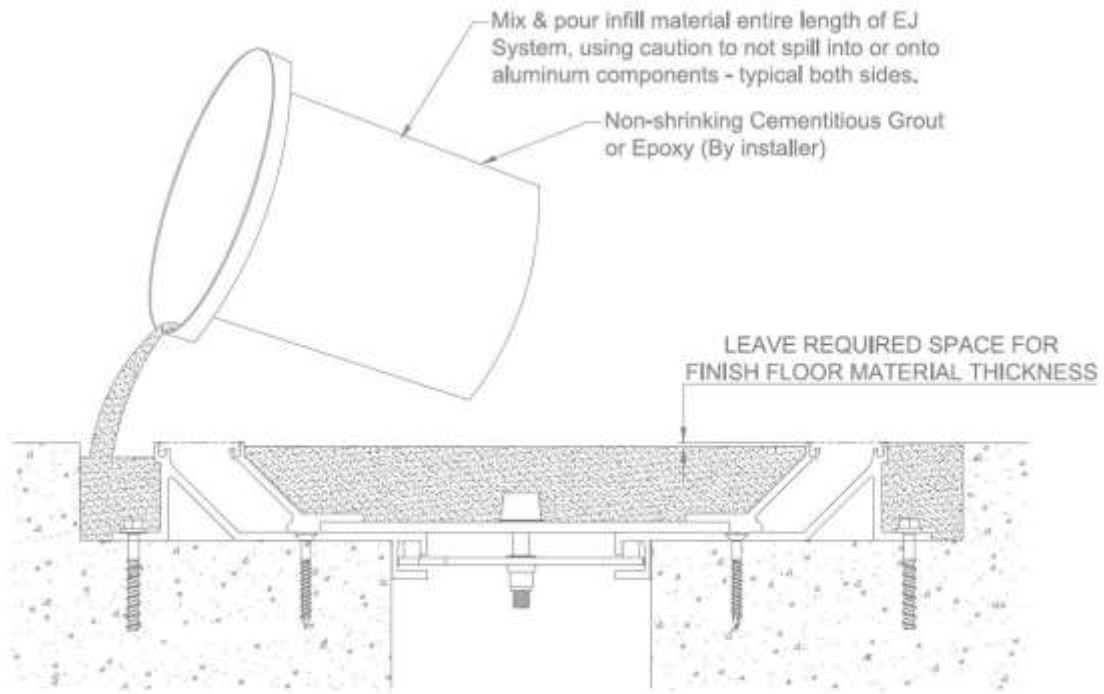

Figure #10

11. Install finished floor material. Be sure to follow the manufacturer's instructions. Joint opening should remain protected throughout this process. **See Figure #11.**

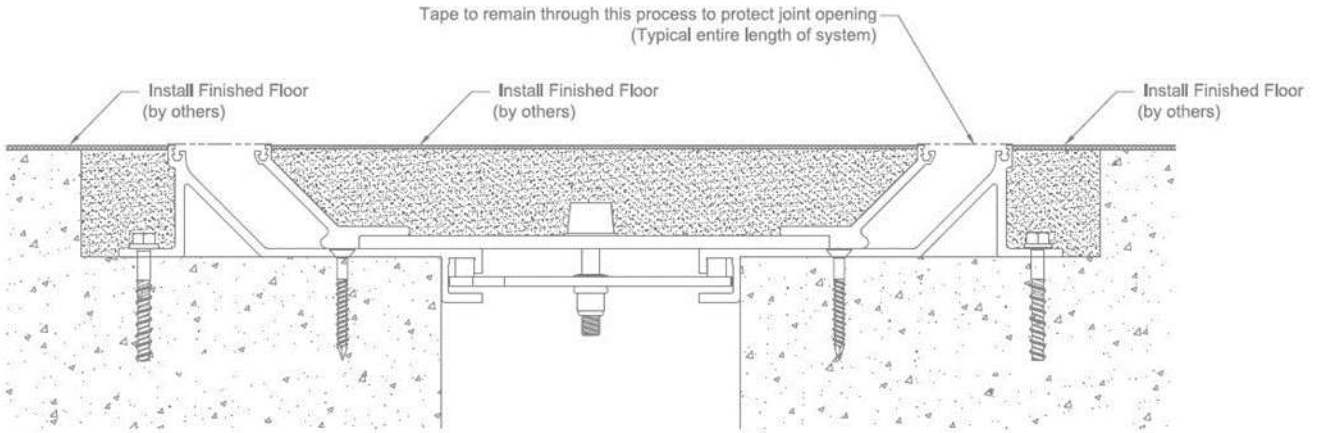

Figure #11

12. Remove heavy tape from joint opening. Install elastomeric seals. Use a vinyl tile roller or similar, to ensure seal tabs completely lock into cavities in aluminum components. Use care not to mark or tear seal. Final seal seams should be offset from all other aluminum seams. Clean off seals using denatured alcohol and a clean rag when complete to remove any construction dust or debris. **See Figure #12.**

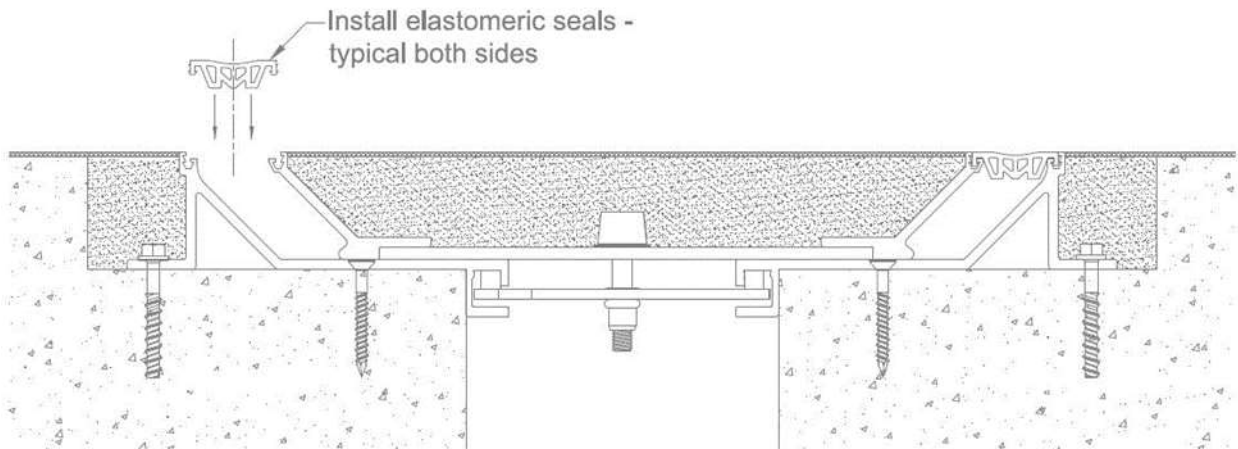
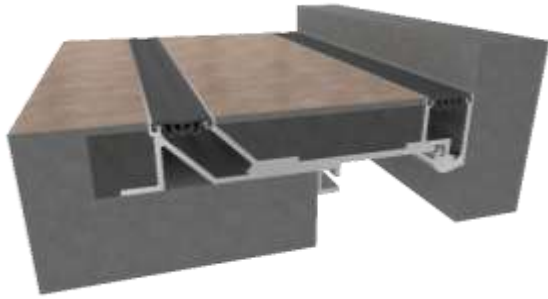

Figure #12

## FLOOR TO WALL COVER SYSTEM – 4” through 16” SIZES ONLY



## GENERAL DESCRIPTION

Nystrom Seismic Flooring Pan System is designed to match the EJN-FLP system in corner applications.

## Pre-Installation

1. Pour slabs with blockouts as shown on shop drawings.
2. Ensure the area where the expansion joint system is being installed (including the blockout area) is smooth and level. High spots should be ground down and low spots filled in. Make sure the substrate is clean by sweeping and/or vacuuming the substrate.

## INSTALLATION

3. After determining that the area is smooth and level, the installer shall inspect opposing concrete slabs, corners and blockouts for acceptability. For repair (if required) refer to Pre-Installation Step #2, also, measure joint opening for proper size as called for on shop drawings and for specific blockout information. **See Figure #13.**

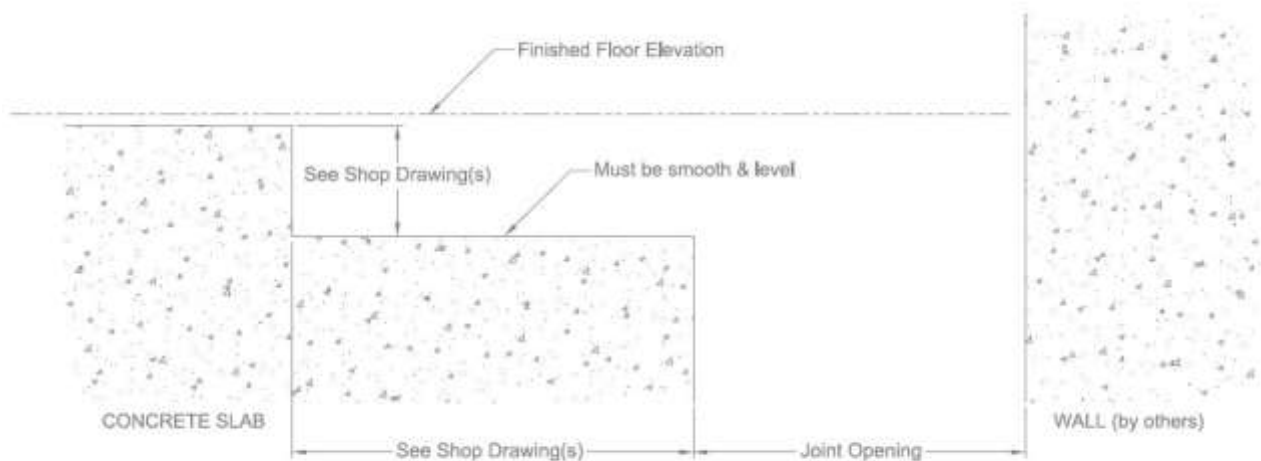

Figure #13

13. On each of the Aluminum Base Members find the “V score marks” to pre-locate the holes you need to drill. After pre-drilling the  $\text{Ø}3/16$ ” holes in the Aluminum Bases per the Shop Drawings, position them in the blockout as shown below. Using the frame as a template, mark and drill  $\text{Ø}3/16$  holes in the blockout for the  $\text{Ø}1/4$ ” Tapcon anchors using the “V score marks” to locate. Set the Aluminum Bases into position and attach with supplied  $\text{Ø}1/4$ ” Tapcons through the previously drilled holes as shown on the Shop Drawings. (Note: stagger seams the entire length of the joint opening – See Step #17 before proceeding.) **See Figure #14.**

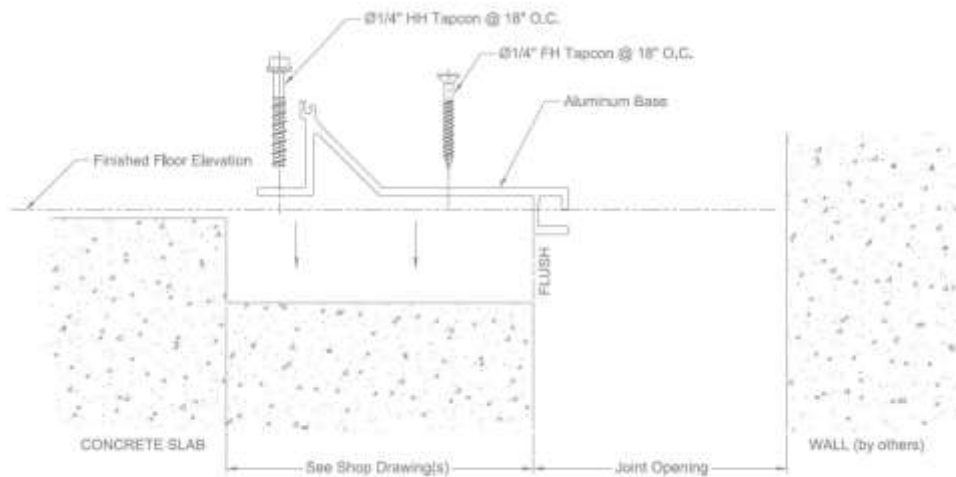

Figure #14

14. In preparation for fastening wall mount extrusion (#32051) pre-drill  $\text{Ø}3/16$ ” holes as shown on the Shop Drawings – use the “V score mark” to properly locate the holes. Hold extrusion against wall and make sure that it is level with the adjacent aluminum edge frame assembly. Snap a chalk line to insure level installation. Use a 5-foot piece wall mount at start of each joint run. Fasten wall mounted aluminum base with  $\text{Ø}1/4$ ” FH Tapcons utilizing the field pre-drilled holes as a template. **See Figure #15.**



Figure #15

15. After aluminum bases are installed, start adding butt splice connections to one end of each aluminum pan. Using the Butt Splice Connector as a template, locate as shown in Figure #16. From the top, mark and drill the two  $\text{Ø}3/16$ " holes at one end of each pan. When assembling in block out, use  $\text{Ø}1/4$ " screws provided (#30032) as shown below. Connectors should be placed in the inside bottom of the pan at one end – one per pan assembly. **See Figure #16.**

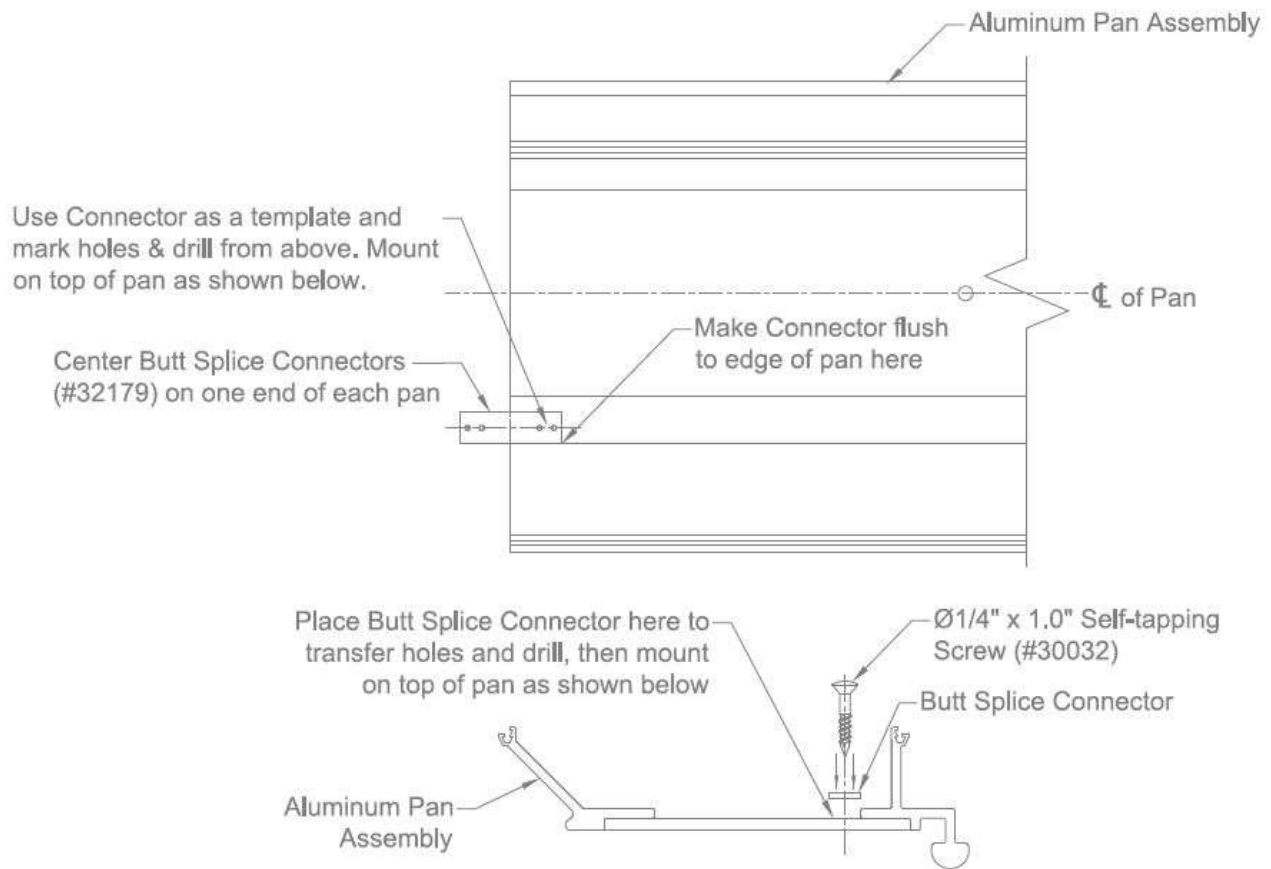

Figure #16

16. Gently set aluminum pans into place as shown above. **See Figure #17.**

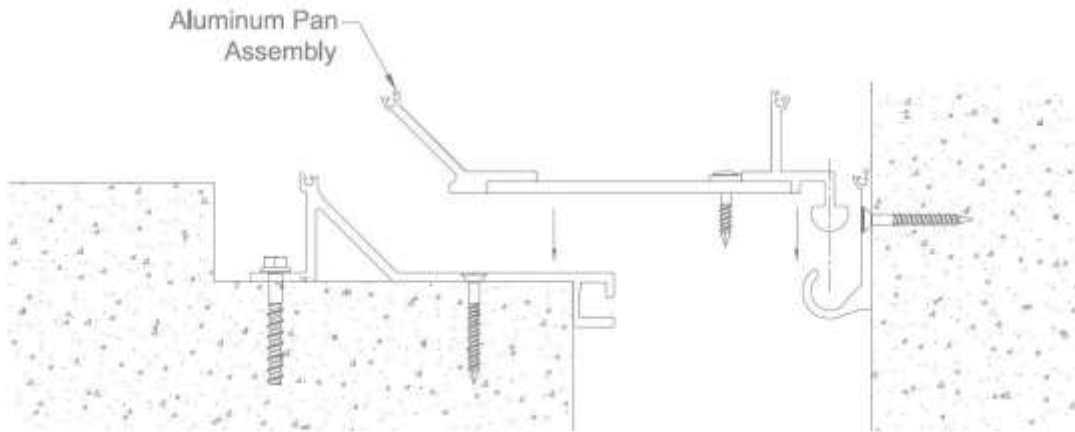

Figure #17

17. Repeat Steps #13 through #16 to align all sections of aluminum pans and aluminum bases. Ensure aluminum pan sections butt tightly together and that the outside edges align from section to section. Confirm all the Aluminum Pans are butted tightly together, and all butt splice connectors are installed properly. **See Figure #18.**

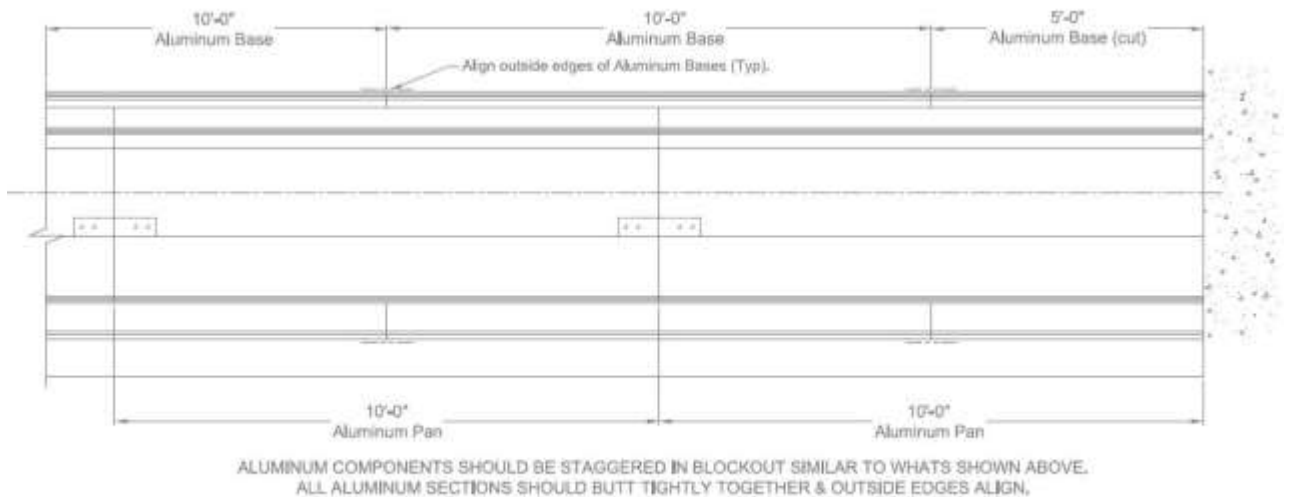

Figure #18

18. Use Duct Tape or similar heavy tape continuously on each side of the EJ System to protect joint opening through the next final steps. **See Figure #19.**

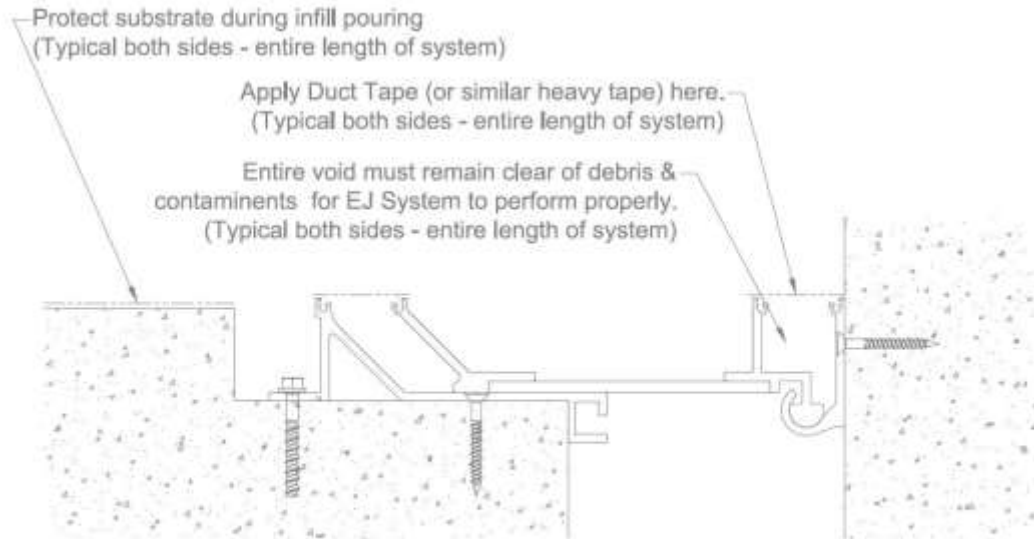

Figure #19

19. Before mixing the infill material care should be taken to remove all dust and debris from the blockout areas and inside the aluminum pan. All surfaces must be clean and dry prior to installing infill. Pour infill material into blockout voids and pan cavity. \*Warning! Leave required recess for floor finish, finish material thickness, and proper placement. **See Figure #20.**

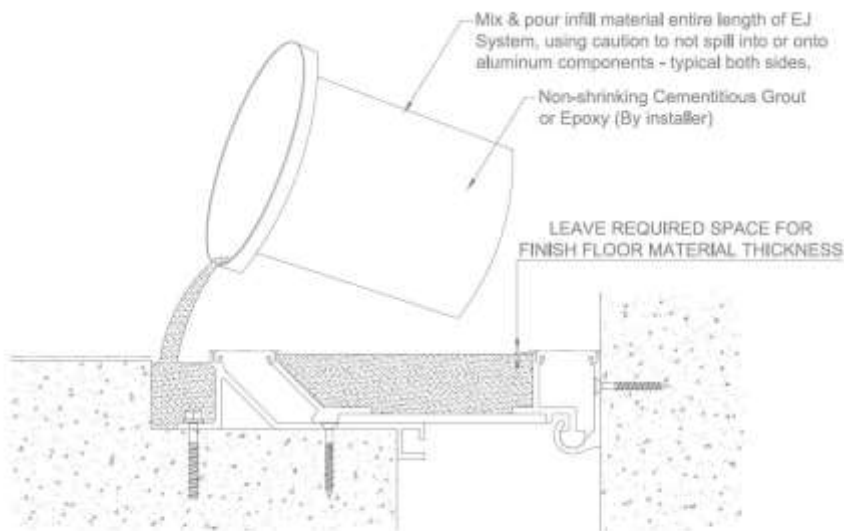

Figure #20



20. Install finished floor material. Be sure to follow the manufacturer’s instructions. Joint opening should remain protected throughout this process. **See Figure #21.**

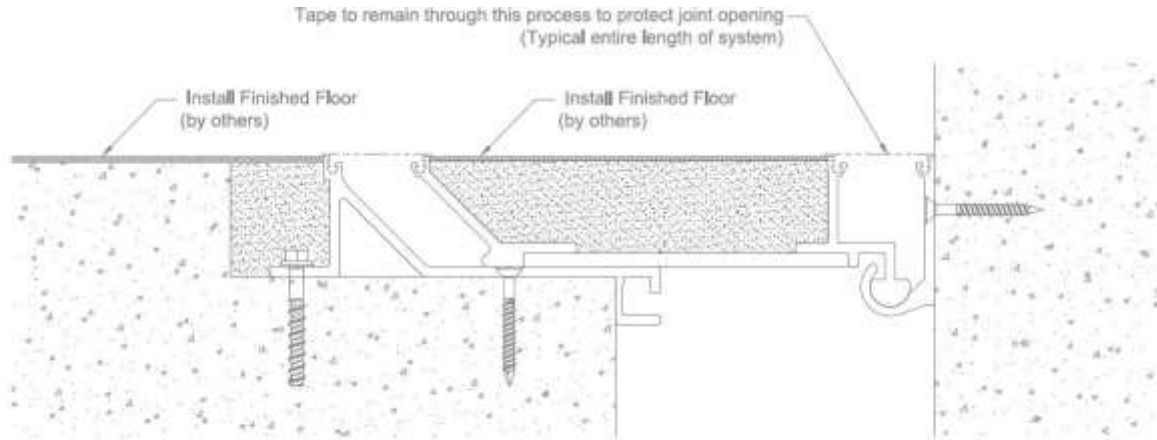

Figure #21

21. Remove heavy tape from joint opening. Install elastomeric seals. Use a vinyl tile roller or similar to ensure seal tabs completely lock into cavities in aluminum components. Use care not to mark or tear seal. Final seal seams should be offset from all other aluminum seams. Clean off seals using denatured alcohol and a clean rag when complete to remove any construction dust or debris. **See Figure #22.**

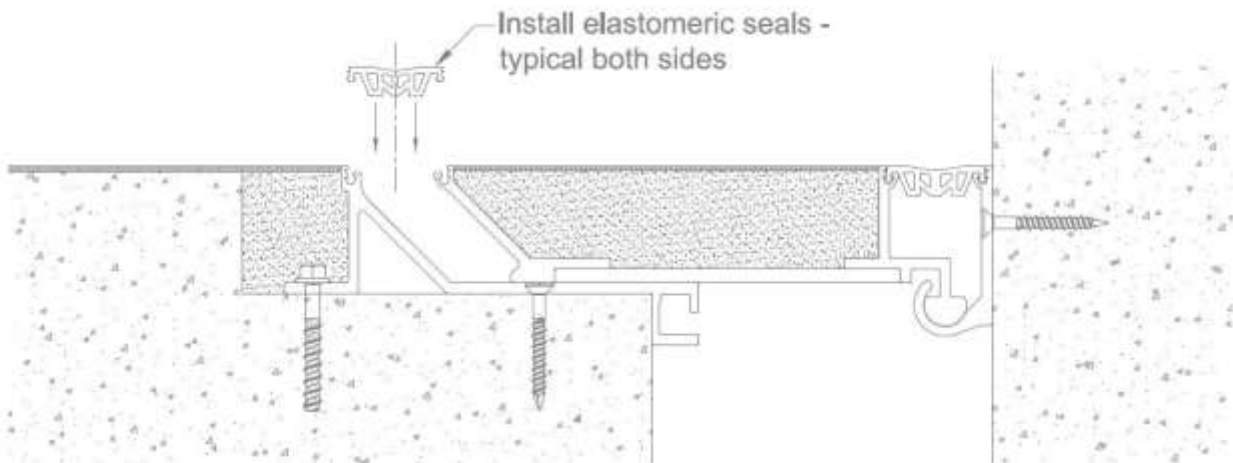

Figure #22

## **OPERATION**

Expansion Joints are designed and built for years of dependable service.

## **MAINTENANCE**

Perform annual inspections to make sure the system is still in position; all fasteners are tight and in place and there is no impedance of joint cover movement. Repair and/or replace as needed.

## **QUESTIONS?**

For more information on installation, repair or replacement, please contact Customer & Sales Support at 800-547-2635 or visit [nystrom.com](https://www.nystrom.com)