

ELASTOMERIC SYSTEM – BLOCKOUT

MODEL(S): EJM-LCF/LCFw

LCF Floor to Floor Cover System

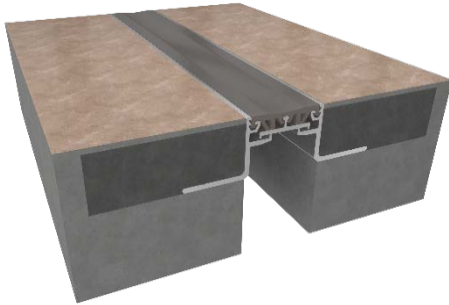

GENERAL DESCRIPTION

This Elastomeric System is built to last. The system's extruded aluminum base is installed in a concrete blockout channel and back-filled in. Integrated into the system is a colored seal that expands and compresses with horizontal movement.

GENERAL SAFETY PRECAUTIONS Improper selection, installation, or use can cause personal injury or property damage. It is solely the responsibility of the user, through their own analysis, to select products suitable to the specific application requirements, ensure proper maintenance and use as intended. Follow local, state, and federal regulations for proper installation and operation requirements.

Introduction + Safety

Please read the complete instructions carefully before beginning any work. To ensure proper installation and performance of the product, the following actions must be completed by the installing contractor. Failure to do so will affect product warranty.

Transportation + Storage

- Inspect all shipments and materials for missing or damaged components and hardware.
- Material must be stored in a clean, dry location.

Preparation

- Locate the packing slip(s) and/or shop drawings.
- Verify that all products listed on the packing slip are included in the package.
- Check the products for damage. If products are damaged, report a freight claim immediately and leave the products in their packaging. If you sign for products without reporting damage, you waive your right to a freight claim and will be responsible for their replacement cost.
- Read the instructions thoroughly before beginning installation.

Tool List

- Tape measure
- Phillips
- Hex screwdriver
- Slotted Drivers for Anchors
- Levels
- Awls
- Masking tape
- Rubber mallet
- Wooden block
- Trowel
- Chop saw to cut product to length
- Electric drill with 5/32” masonry bit
- Broom & dustpan or vacuum
- Adhesive glue

Included with the expansion joint system:

- 3/16” x 1-3/4” Tapcon fastener

Preinstallation

1. Pour floors with blockouts as shown on shop drawings. Make sure the depth of the blockout takes the thickness of the finished floor into account.
2. Ensure that the blockout is smooth. High spots should be ground down and low spots filled in. Make sure the blockout is clean by sweeping and/or vacuuming.

INSTALLATION

1. Drill 3/16” holes into base frames along a line 1/2” from the leg edge. Holes should start 2” from each end and be spaced 18” o.c. **See Figure 1**

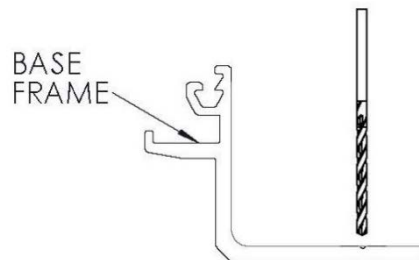

FIGURE 1

2. Position base member frames in blockout per shop drawings. Using the frames as a template, mark and drill 5/32” holes in the concrete. Install base member frames in the blockout opening with supplied Tapcon fasteners, making sure not to over tighten. **See Figure 2**

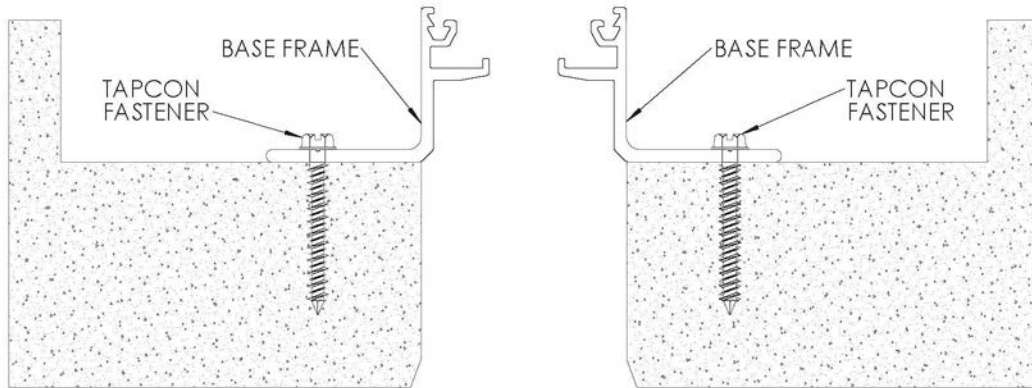

FIGURE 2

3. Place slide plate (not required on 1” joint sizes) in the lower channels of the base frames with the bent ends of the plate pointing downwards. **See Figure 3**

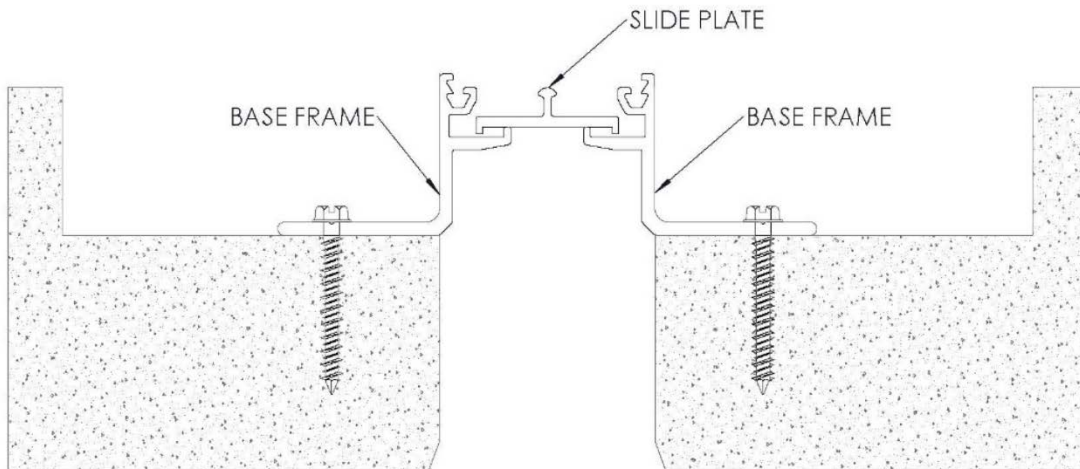

FIGURE 3

4. Position the elastomeric seal into position and push the seal bulbs into the base frame top channels as shown. Make sure the bulbs are seated all the way into the channel. Also, make sure the bottom center channel in the seal is pushed over the protrusion on the slide plate (not required on 1” joint sizes). **See Figure 4**

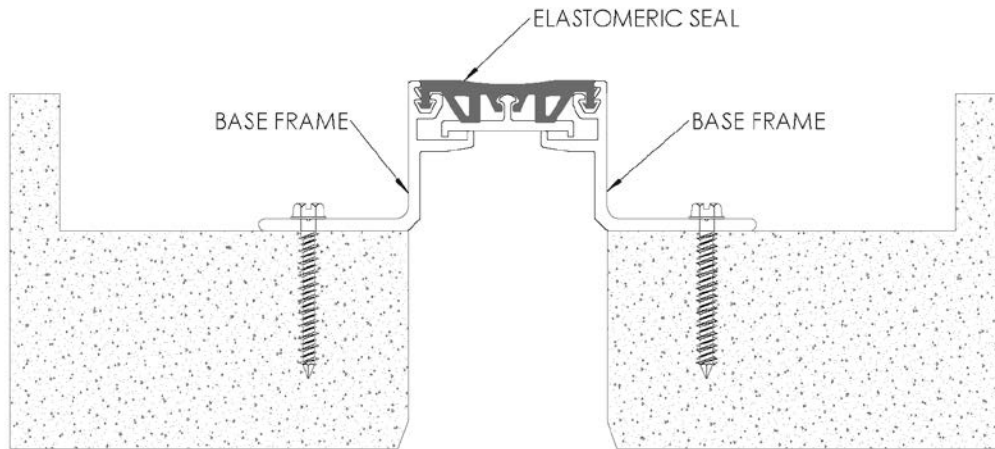

FIGURE 4

5. Protect the exposed surface of the expansion joint, then using an appropriate infill material (by others), fill in the blockout level with the surrounding floor. **See Figure 5**

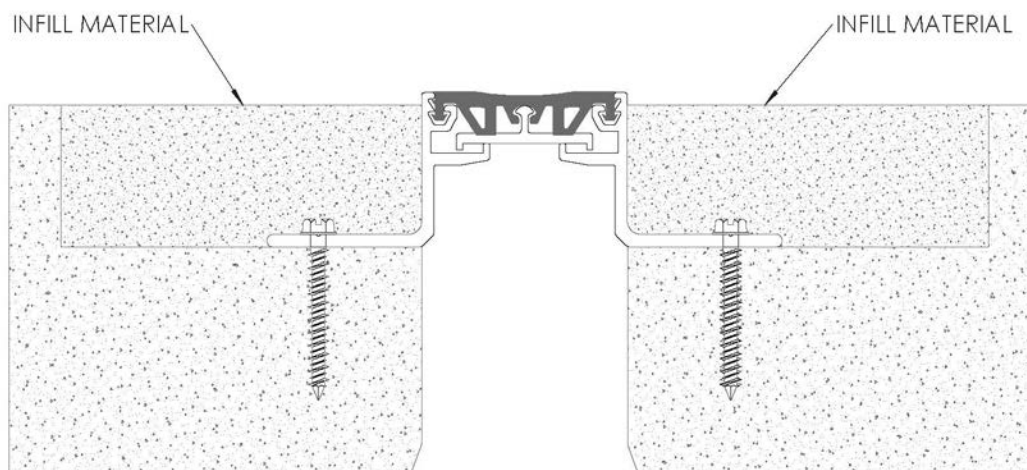

FIGURE 5

- 6. After infill material has cured, finished floor (by others) may now be installed.
See Figure 6

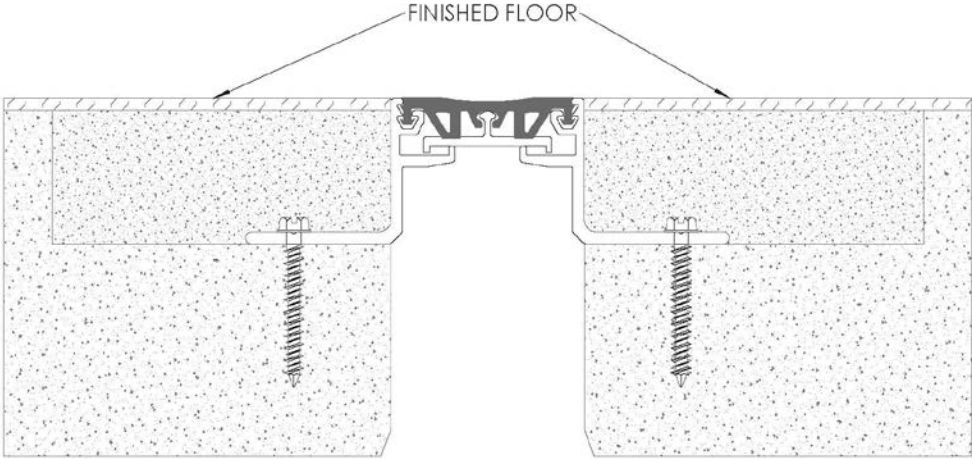

FIGURE 6

LCFw Floor to Wall Cover System



GENERAL DESCRIPTION

Nystrom LCFw Interior Cover System is designed to match the LCF cover plate in floor to wall applications.

Included with the expansion joint system:

- 3/16" x 1-3/4" Tapcon fastener

Preinstallation

1. Pour floors with blockouts as shown on shop drawings. Make sure the depth of the blockout takes the thickness of the finished floor into account.
2. Ensure that the blockout is smooth. High spots should be ground down and low spots filled in. Make sure the blockout is clean by sweeping and/or vacuuming.

INSTALLATION

1. Drill 3/16" holes into base frame along a line 1/2" from the leg edge. Holes should start 2" from each end and be spaced 18" o.c. **See Figure 1**

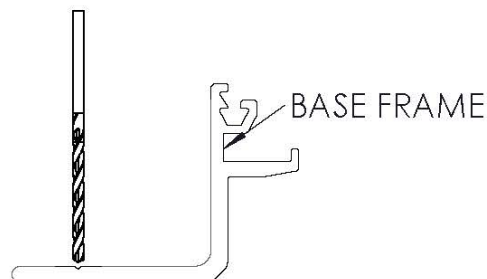

FIGURE 1

2. Position base member frame in blockout per shop drawings. Using the frame as a template, mark and drill 5/32” holes in the concrete. Install base member frame in the blockout opening with supplied Tapcon fasteners, making sure not to over tighten.

See Figure 2

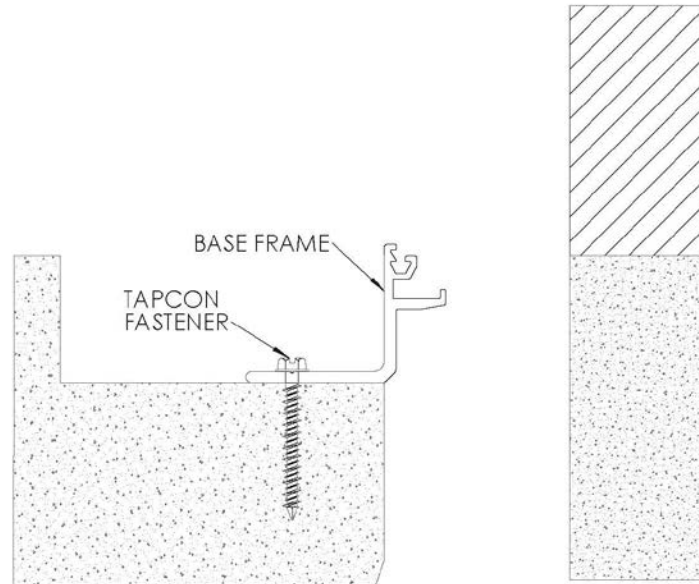

FIGURE 2

3. Position the wall frame into position, making sure the top channel is level with the top channel of the base frame. Attach the wall frame to the wall with appropriate fasteners (by others) for the wall type 18" o.c. **See Figure 3**

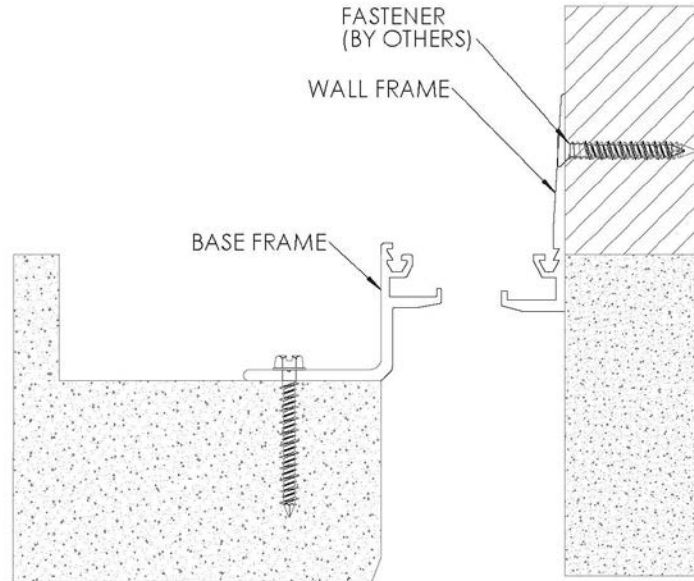

FIGURE 3

4. Place slide plate (not required on 1" joint sizes) in the lower channel of the base frame and wall frame with the bent ends of the plate pointing downwards. **See Figure 4**

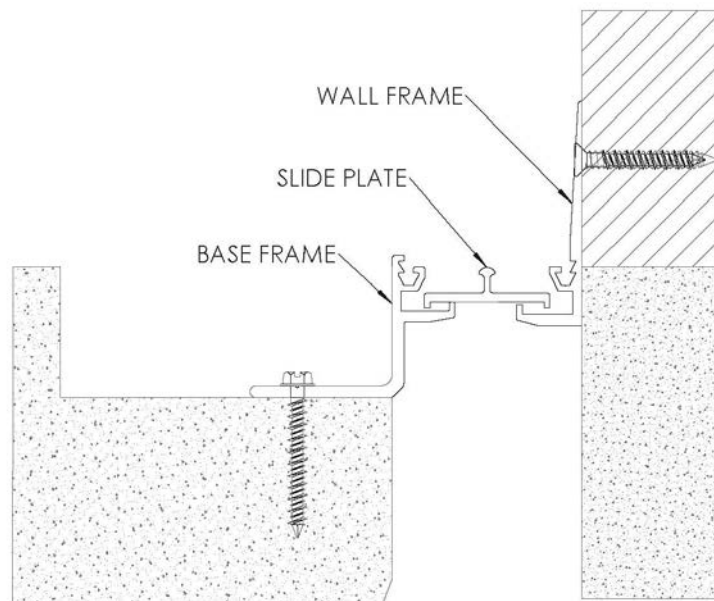

FIGURE 4

5. Position the elastomeric seal into position and push the seal bulbs into the base frame and wall frame top channels as shown. Make sure the bulbs are seated all the way into the channel. Also, make sure the bottom center channel in the seal is pushed over the protrusion on the slide plate (not required on 1” joint sizes). **See Figure 5**

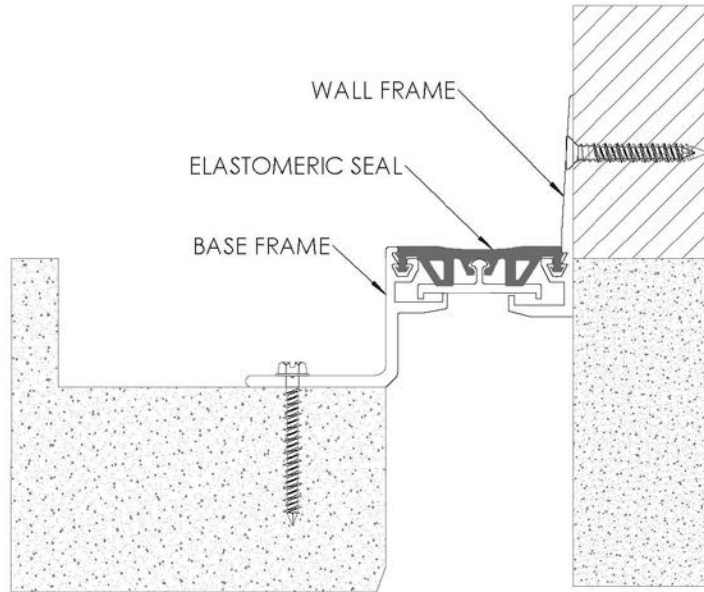

FIGURE 5

6. Protect the exposed surface of the expansion joint, then using an appropriate infill material (by others), fill in the blockout level with the surrounding floor. **See Figure 6**

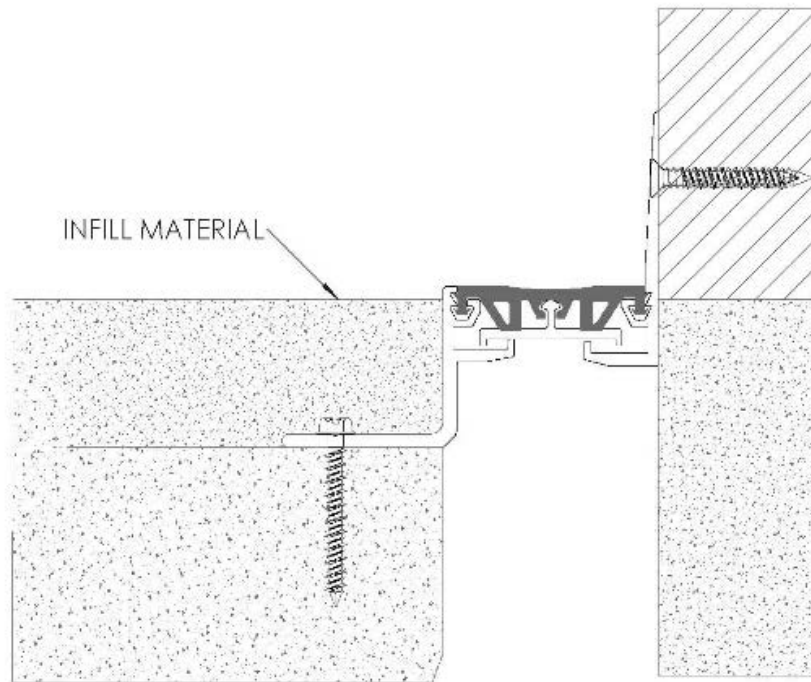

FIGURE 6

7. After infill material has cured, finished floor (by others) may now be installed. **See Figure 7**

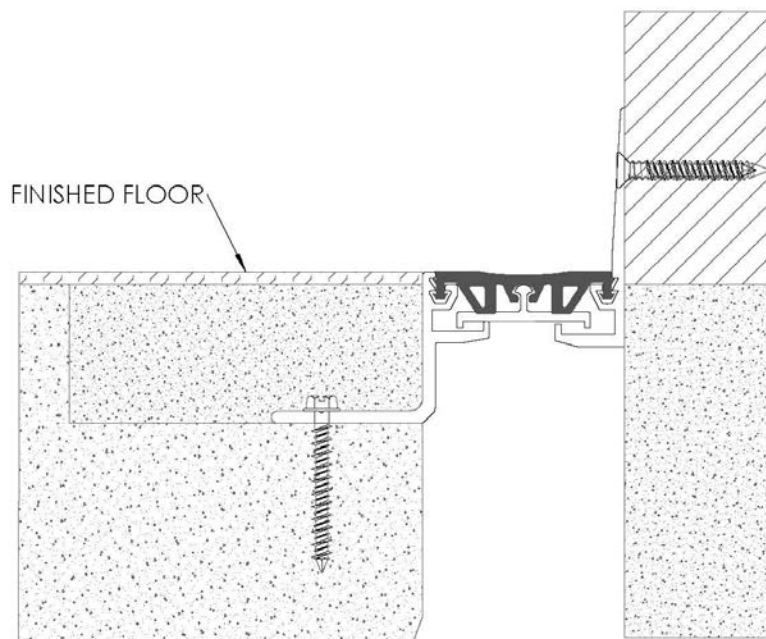

FIGURE 7

FIELD SPLICE FOR FLAT ELASTOMERIC SEAL

1. Determine the angle needed and cut ends of seal in a miter box with a sharp, non-serrated knife. **See Figure 1**

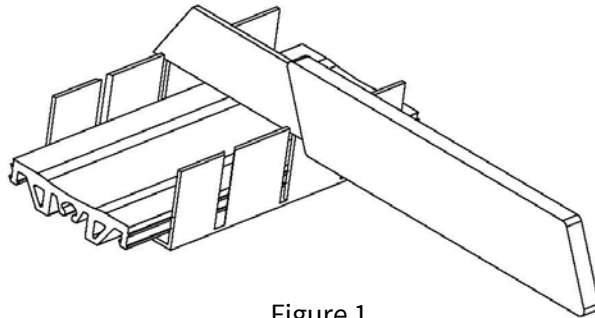

Figure 1

2. Using a solvent (by others) that is safe for elastomeric materials clean the ends of the seals. **See Figure 2**

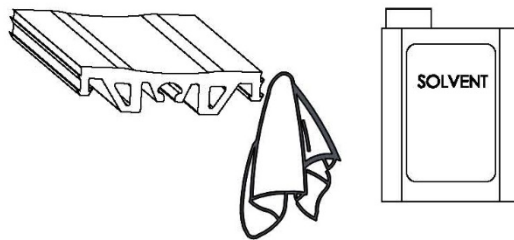

Figure 2

3. Apply super glue, cyanoacrylate type (non-gel) or similar adhesive (by others) and follow instructions by the adhesive manufacturer. **See Figure 3**

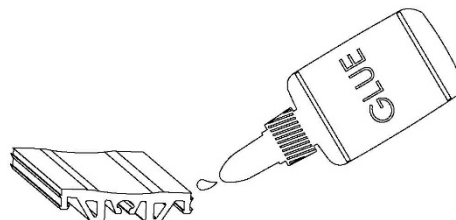

Figure 3

4. Check the splices after the adhesive has cured and reapply adhesive as necessary. Allow 15 minutes prior to installing seal. It typically takes 24 hours for adhesive to fully cure and achieve proper working strength. Ensure that the splice of the seal is not within 2” of a joint in the aluminum extrusion. **See Figure 4**

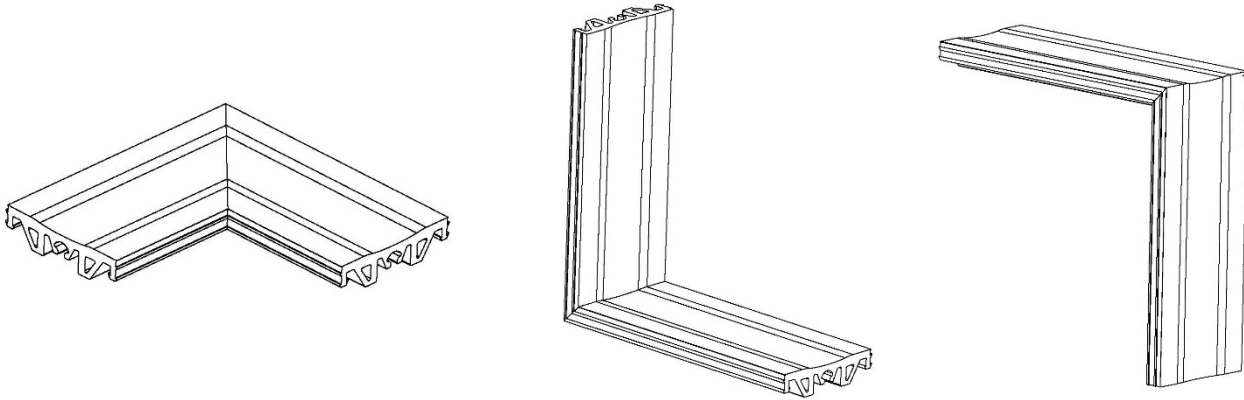

Figure 4

OPERATION

Expansion Joints are designed and built for years of dependable service.

MAINTENANCE

Annual inspections should be performed to make sure the system is still in position. Repair and/or replace as needed.

QUESTIONS?

For more information on installation, repair or replacement, please contact Customer & Sales Support at 800-547-2635 or visit nystrom.com