

SEISMIC PRE-COMPRESSED HEAVY DUTY FOAM SYSTEM – RECESSED APPLICATION

MODEL(S): PDX

PDX Slab to Slab System – 1” Through 4” Sizes

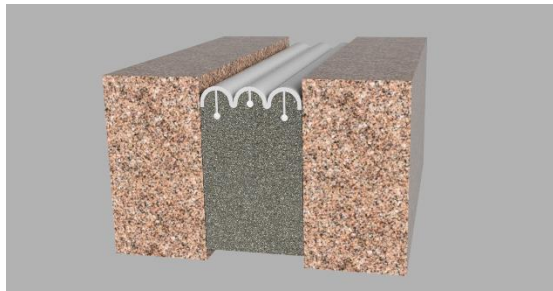

GENERAL DESCRIPTION

The Nystrom Seismic Pre-Compressed Heavy Duty Foam System is a watertight joint system designed for high trafficked areas. Fiberglass rods allow this system to hold up against high movement and heavy pedestrian and cart loads.

GENERAL SAFETY PRECAUTIONS Improper selection, installation, or use can cause personal injury or property damage. It is solely the responsibility of the user, through their own analysis, to select products suitable to the specific application requirements, ensure proper maintenance and use as intended. Follow local, state, and federal regulations for proper installation and operation requirements.

Introduction + Safety

Please read the complete instructions carefully before beginning any work. To ensure proper installation and performance of the product, the following actions must be completed by the installing contractor. Failure to do so will affect the product warranty.

Transportation + Storage

- Inspect all shipments and materials for missing or damaged components and hardware.
- Material must be stored in a clean, climate-controlled, dry location.

Preparation

- Locate the packing slip(s) and/or shop drawings.
- Verify that all products listed on the packing slip are included in the package.
- Check the products for damage. If products are damaged, report a freight claim immediately and leave the products in their packaging. If you sign for products without reporting damage, you waive your right to a freight claim and will be responsible for their replacement cost.
- Read the instructions thoroughly before beginning installation.

Tool List

- Tape measure
- Serrated edge knives
- Acetone or isopropyl alcohol, lint free rags & a clean paint bucket
- Caulking gun & caulk knives
- Spray bottle filled with water
- Chemical-resistant gloves
- Broom & dustpan or vacuum
- Level
- Painter tape and/or duct tape
- 6” caulkers knife
- Hacksaw
- Ø1-1/2in “jiffy mixer”
- Spatula to scrape epoxy

Environmental Storage Requirements

- Cold Days: Store materials off the floor in a clean, dry location, inside above 68°F (20 °C) for a minimum of 24 hours prior to installation. Product will recover slower when it’s cold and faster when it’s warm.
- Hot Days: Keep materials in a clean, dry location and out of direct sunlight when the temperature is greater than 60°F until immediately prior to installation of joint. Do not store material in an enclosed container where temperatures exceed 100 °F (38 °C).

Sidewall Adhesive information for Horizontal Joints

For horizontal joints, the sidewall adhesives are required as they support the joints performance.

PREINSTALLATION

Concrete:

1. Remove loose particles and weak or unsound concrete or other substrate materials to ensure a solid, sound substrate. Spalls, chipped edges, and uneven surfaces must be repaired using proper material and methods to ensure maintenance of the fire-rated wall assembly construction. Joint faces must be parallel.
2. Joint must have unobstructed depth greater than or equal to the full depth of the largest material supplied plus 1/2" (6mm).
3. Remove all contaminants by sandblasting or grinding to ensure a thoroughly clean and sound substrate for the full sealant depth.
4. NOTE: DO NOT use a wire wheel – this will polish the substrate and cause bond-failure.
5. Dry all wet surfaces.
6. NOTE: Do not use flame or excessive direct heat to dry substrate – this will leave carbon on the substrate and cause bond failure.
7. Wipe joint faces with dampened, lint-free rags to remove all concrete dust and contaminants
8. Ensure joint sides are dry of solvent or cleaning agent PRIOR to installation.
9. Worksurfaces on both sides of the joint opening must be protected using roofing paper or similar.
10. Tape top 1/2" of joint opening (see Figure "A" below) both sides, to prohibit epoxy / supplied adhesive accessory from this area. Failure to stop epoxy from landing in this area will restrict foam seal from optimal movement.

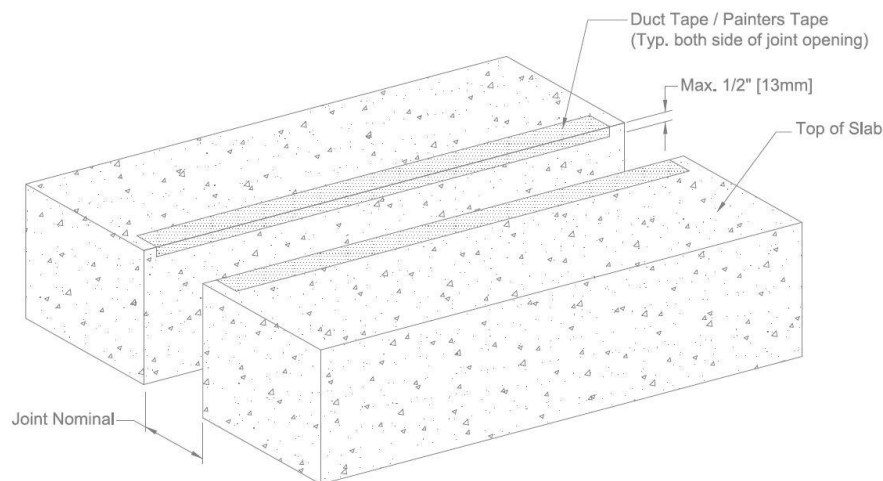

Figure #A

Metal:

1. Sandblast or grind to rough, white metal and solvent-wipe immediately prior to applying epoxy.

IMPORTANT: Ensure that there is no oxidation (rust) on metal substrate before the epoxy is applied.

Foam and accessory materials:

1. Keep material warm (~70° F) for 24 hours before installation.
2. Tape the top of the joints ahead of time (will help avoid bad installations). Epoxy / adhesive accessories / sealant accessories on ribbed face of joint will restrict movement.
3. Use (1) thickness of the 1/4” MDF sideboard and run along joint to ensure a consistent 1/4” recess.

INSTALLATION (EJN-PDX)

1. Open the correct box.
 - Material has been supplied to your mean-temperature field measurement of joint widths. Joint widths for material supplied are marked at the end of each box.
 - Find the correct box and open it.
 - Compare material width marked on each stick against joint width.
 - The actual material width measured between the hardboard will be slightly less than the indicated joint width. If unsure of correct material selection, consult Nystrom immediately.
2. **DO NOT REMOVE outer plastic packing until you read the rest of these instructions.**
 - Proper performance of expansion seals necessitates proper installation beginning through completion.
 - Improper handling will cause product to expand prematurely.
 - Failure to follow these instructions may result in system failure and warranty issues.

3. Use a miter saw to make any cuts for transitions or splices BEFORE removing the outer plastic packaging.
 - Be sure to use a blade suitable for cutting fiberglass to avoid splintering the fiberglass rods contained inside the product.
 - All starting and ending pieces must be square to the termination point.
 - **IMPORTANT:** Do not remove outer plastic packaging until you are ready to install the material in the joint opening – See Step #7.

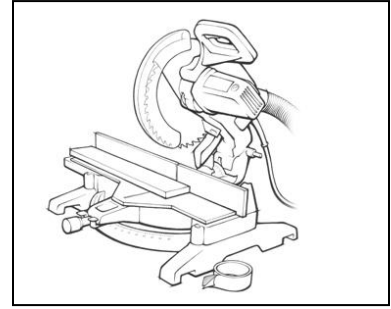

4. Epoxy notes:
 - Mix only the required amount of epoxy adhesive that will be used within 30 minutes.
 - Application and surface temperatures should be at least 40°F (4 °C) & rising.
 - Greater volume = less time to cure, smaller volume = more time to cure.
 - As ambient temperatures increase, epoxy adhesive cures twice as fast.
 - As ambient temperatures decrease, epoxy adhesive cures half as fast.
 - To increase the pot life of the epoxy adhesive, split up the mixed material into smaller units.
 - Epoxy adhesive must be wet upon installation of EJM-PDX. As shown above, the working time is approximately 30 minutes, temperature dependent.
 - If epoxy adhesive hardens prior to installation, another coat may be applied within 8 hours. After 8 hours, the joint surface must be abraded prior to recoating with the epoxy adhesive.
 - If the entire contents of containers are not required, reseal each container and store as defined on page 2, allowing epoxy to be stored and/or reused at another installation.
5. To mix epoxy adhesive:
 - Mix Part A and Part B separately.
 - Transfer enough contents of Part A for the current installation into a clean container. Form a “bowl” of Part A material in the clean container by pulling some Part A material up the inside of the container, this will greatly aid in the mixing of Parts A & B together as Part B may stick to the sides of the container. Then transfer the equal parts of Part B into the same container. Mix the combined material thoroughly with a low-speed drill

or jiffy mixer. Mix until the black and white colors combine and there are no remaining streaks of either color.

- Transfer the combined material into a new clean container to prevent unmixed residue from contaminating the final mixture.

6. Apply epoxy adhesive to substrate:

- Begin installation at one end of the joint opening and work in one direction.
- Apply a 1/16" to 1/8" thick coating of epoxy adhesive to both sides of the substrate using a 6" caulking knife to the depth of the foam plus 1/2" (13mm). **See Figure #1.** The epoxy adhesive must be wet upon the installation of the EJN-PDX foam.
- Once epoxy adhesive is applied, proceed to Step #7.

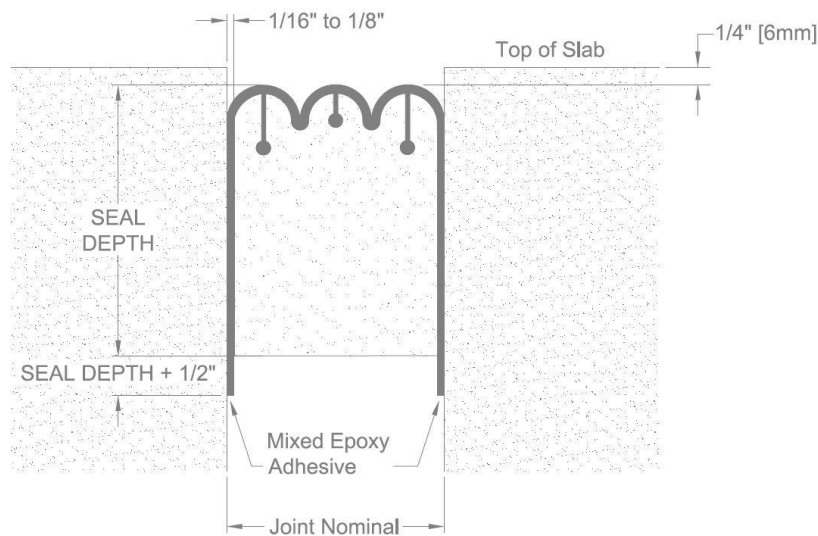

Figure #1

7. When ready to install the foam, open the plastic packaging by:

- The foam seal is held under compression by hardwood and plastic wrapping. When ready to install, slit the plastic wrapping by cutting along the hardboard and inner release liner.
- **DO NOT CUT ALONG SILICONE-COATING FACE. YOU MAY CUT THROUGH IT, THUS DAMAGING THE SEAL.**
- Remove the plastic packaging and the hardboard from both sides of the foam.
- Once the packaging is removed, be prepared to install the material immediately after removing the plastic packaging to ensure the material does not expand past the joint.

8. Installing the foam:

- Place the material into the joint opening while gently pushing the adhesive against the side of the opening. The silicone coating of the foam should be placed at a minimum of 1/4" (6mm) below the substrate surface. Use the 1/4" MDF as discussed in Preinstallation: foam on page 3.
- Feed material into joint, working sequentially in one direction starting at one end of the joint.
- Always push material – DO NOT PULL IT – to prevent stretching.
- Once the material is in place, use a clean margin trowel to firmly press the adhesive into the substrate.
- Allow material to expand to fill the joint opening.
- If necessary, use small – approx. 3" – pieces of used hardboard packing as wedges to hold sections in place as they expand.
- Allow 72 hours for full expansion and material equalization. Note: expansion and material equalization rates are affected by temperature.

9. **If splicing is required**, select the piece of EJM-PDX to be spliced. To ensure proper fit and provide compression at splices, cut the final piece of foam for each run including a 1/4" - 1/2" (6-13mm) overlap. Verify both ends are cut square – refer to Step #3. Apply a minimum of 1/4" (6mm) bead of sealant to the mating end of the foam to be installed. **See Figure #2.** Firmly compress new foam seal and foam seal already installed in joint opening.

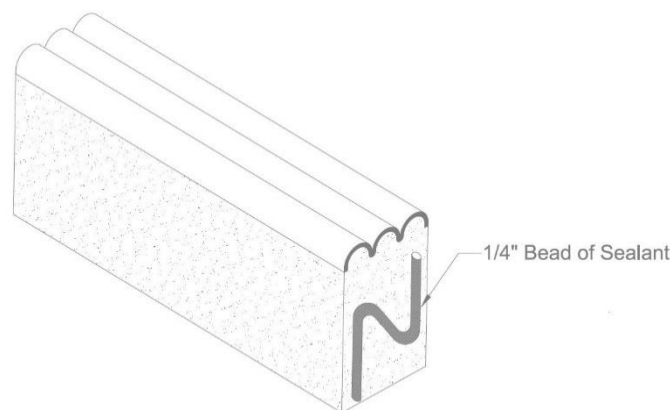

Figure #2

10. Joining successive lengths (refer to **Figure #3** below):

- Work in one direction towards the previously installed length or end of the joint. Do not stretch the material.
- Insert first piece of material as described in Step #8 but leave end protruding up and out of joint.
- Place end of next section against end of first piece (joint #1). Push hard to compress the joint firmly together.
- Leaving joint just made protruding from joint; insert the rest of this section of material into joint.
- Finally push protruding joint section into joint #2.

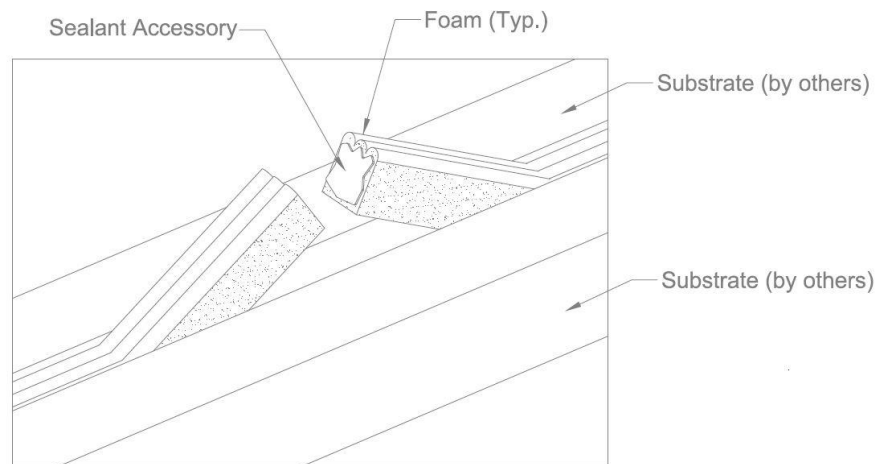

Figure #3

12. Remove duct tape / painter's tape from deck surface and what was draped inside joint opening prior to adhesive kick (typically less than 30 minutes from time of sidewall adhesive installation). Remove any excess epoxy.

13. Apply sealant to edge of facing:

- Once all foam seals are installed, tool silicone over all seams and transitions using a small caulking tool. Evenly spread the silicone on exposed seams for a clean, aesthetically pleasing finish. Fill in any holes or voids in seams with the silicone to fill and seal the joint.

14. Install corner beads:

- Corner beads are required with EJM-PDX.
- Wait until material is expanded fully against both sides of the joint.

- Ensure that material and joint sales are dry if water spray is used to facilitate installation.
- Place a caulking bead where the sealant meets the substrate.
- Tool the corner bead firmly against the substrate and silicone facing.
- Note: less is more here. Only a small bead of silicone is required between the inside surface of the joint opening and the first foam below. Too much silicone will prohibit foam movement.

15. Direction changes:

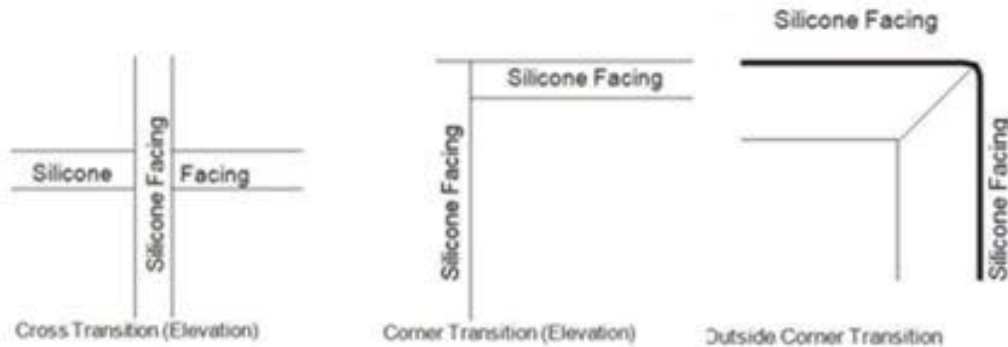

OPERATION

Expansion Joints are designed and built for years of dependable service.

MAINTENANCE

Perform annual inspections to make sure the system is in position; all components are tight and in place and there is no impedance of joint movement. Repair and/or replace as needed.

QUESTIONS?

For more information on installation, repair, or replacement, please contact Customer & Sales Support at 800-547-2635 or visit nystrom.com