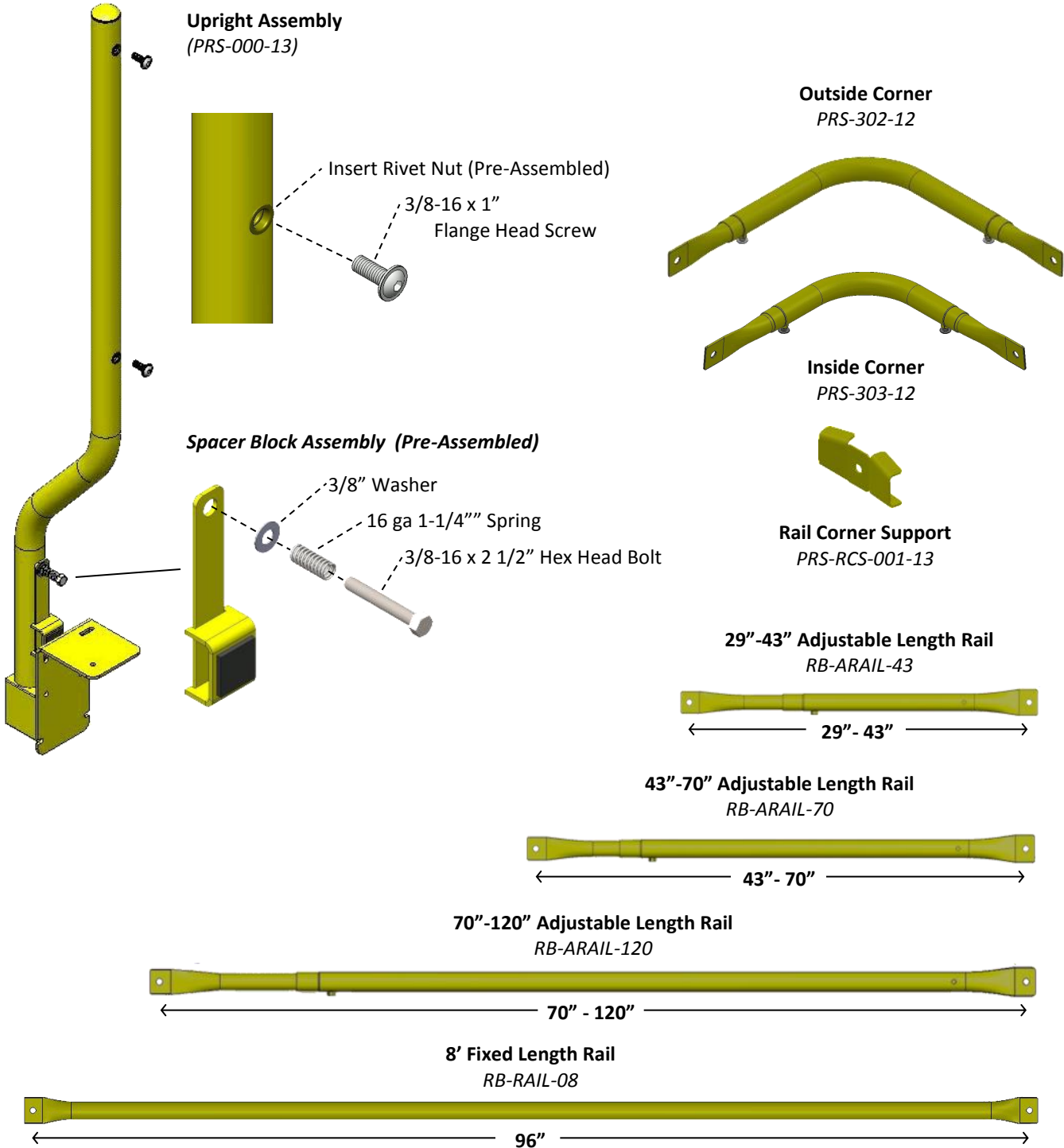
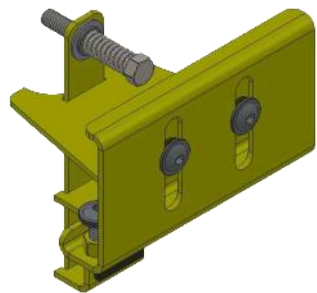

DIAGRAM OF PARTS

The Permanet Guardrail is comprised of numerous components. Below are examples of the individual parts that comprise the system. These parts may or may not be a part of your particular system, and are shown for reference only.





Toe Board Bracket Assembly
(PRS-TB-000-12)

Toe Board

- 60" (PRS-TB-001-60-14)
- 72" (PRS-TB-001-72-13)
- 96" (PRS-TB-001-96-13)
- 120" (PRS-TB-001-120-12)

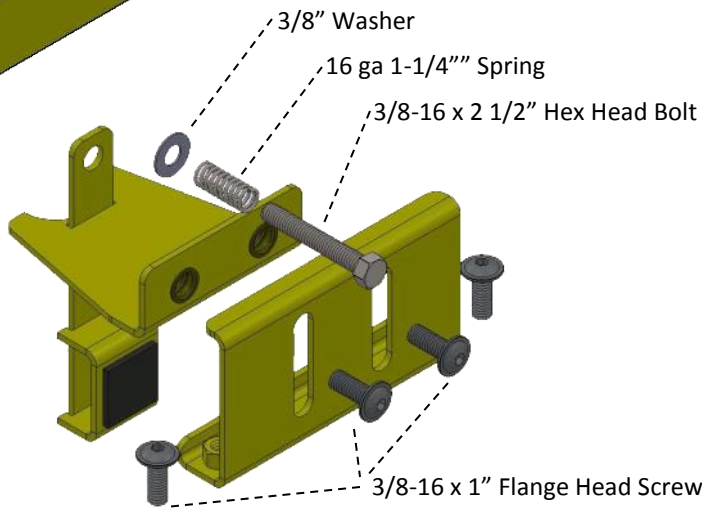
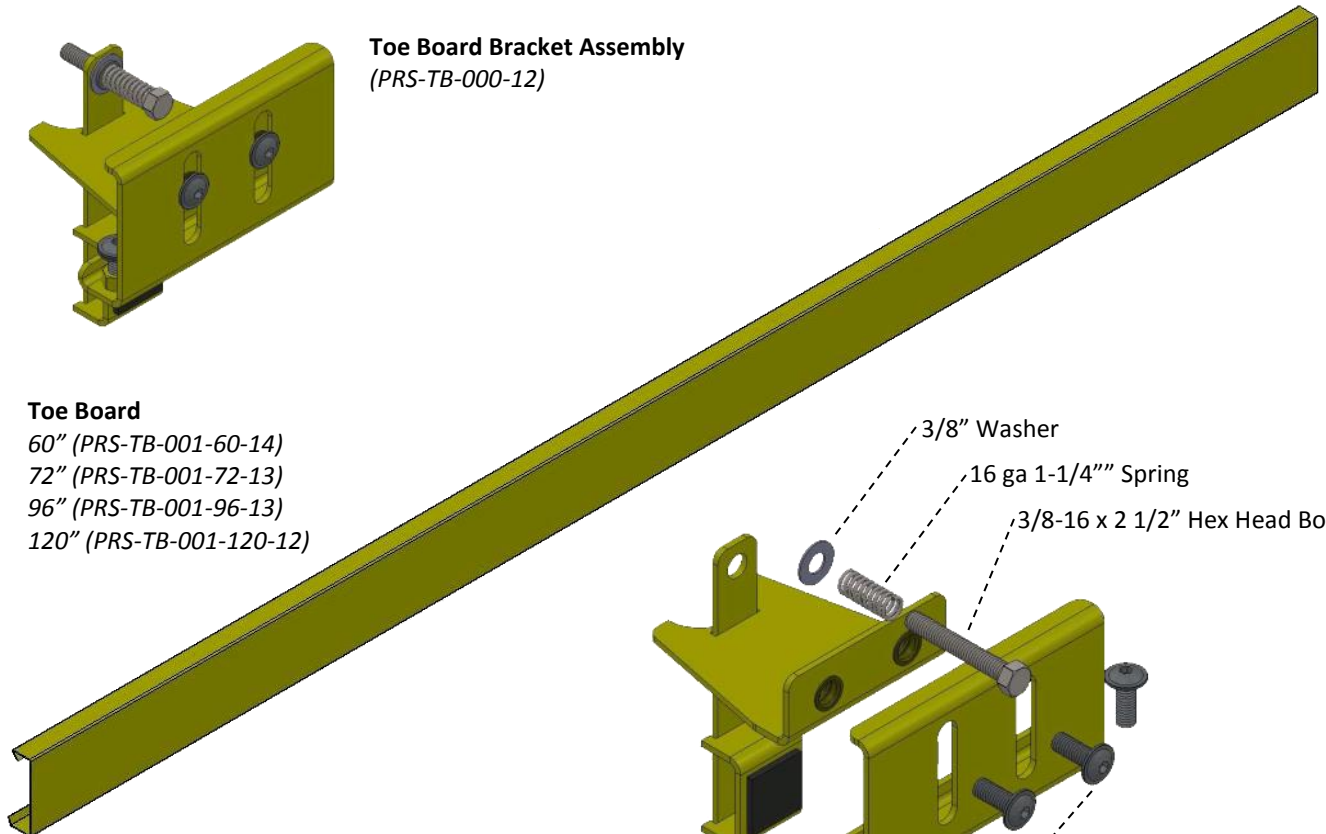

OPTIONAL INTEGRATED LIGHTNING PROTECTION



Aluminum Upright Cap
(A867)

Aluminum Rail Connector
(A865)

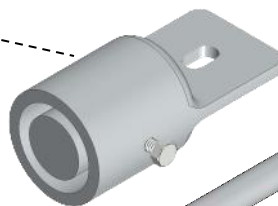

Aluminum Rail Assembly
(A858-80-KIT)

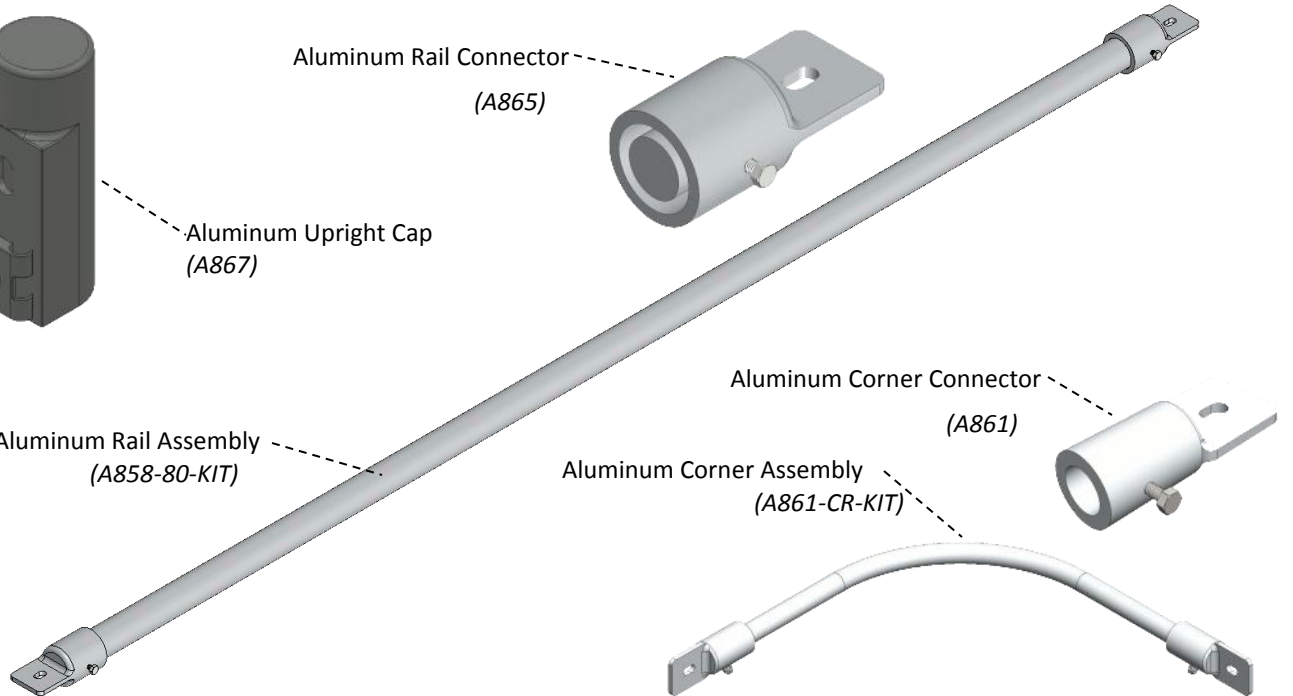

Aluminum Corner Connector
(A861)

Aluminum Corner Assembly
(A861-CR-KIT)

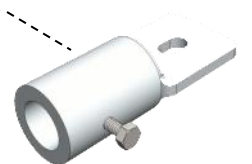

PRIOR TO INSTALLATION

- A competent professional should ensure the substrate is adequate and structurally sound prior to any guardrail installation. Any improvements to the substrate shall be made prior to any guardrail installation.
- Establish the layout of the roof area to be protected. Any object that will interfere with the railing system should be evaluated and considered in the design layout. In most cases, a guardrail layout drawing is provided as a general layout guide. Actual field conditions may require layout modifications from the provided layout drawing.
- Recommended Fasteners:
 - Single Wood Nailer—1/4" x 1-1/2" GRK RSS Structural Screws
 - Double Wood Nailer—5/16" x 2-1/2" GRK RSS Structural Screws
 - Concrete—1/4" x 1-1/4" through 2-1/4" GRK Caliburn PH Screws
(1" minimum penetration is required)
 - Other Substrates— Consult Leading Edge Safety technical department.
- Begin installation at the corners and work toward the middle of the edge being guarded.

STEP 1—Determine the first corner from which work will begin. To ensure proper placement of the corner uprights, place each upright 20-1/2" from the outside corner of the structure (see Figure 1.1). Ensure uprights are plumb and the vertical face of the mounting bracket is flush with the substrate (Figure 1.2); attach to structure with appropriate fasteners (see Figure 1.3). Inside corner placement, see Figure 1.4.

TIP—FASTENING THE FACE TO THE STRUCTURE FIRST WILL HELP ENSURE THE BRACKET IS FLUSH WITH THE STRUCTURE.

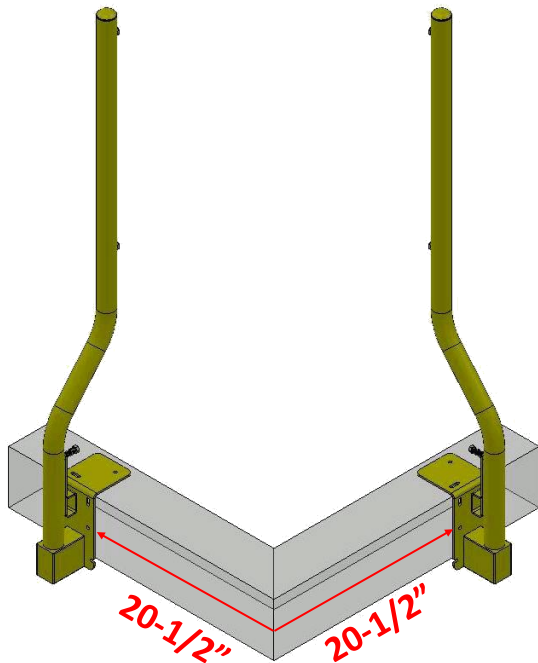

Figure 1.1
(OUTSIDE CORNER)

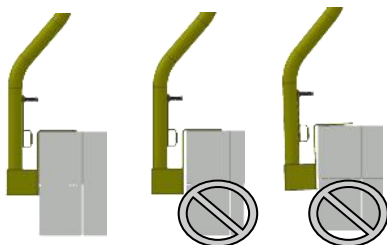

Figure 1.2

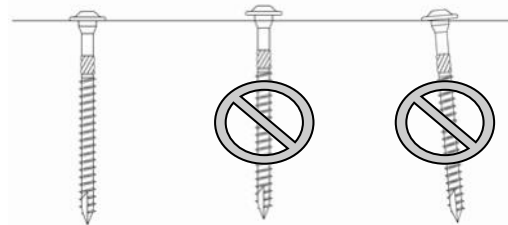

Figure 1.3

*****Proper and secure fastening requires the fasteners are installed straight and fastener heads are flush and tight to the surface of the bracket.**

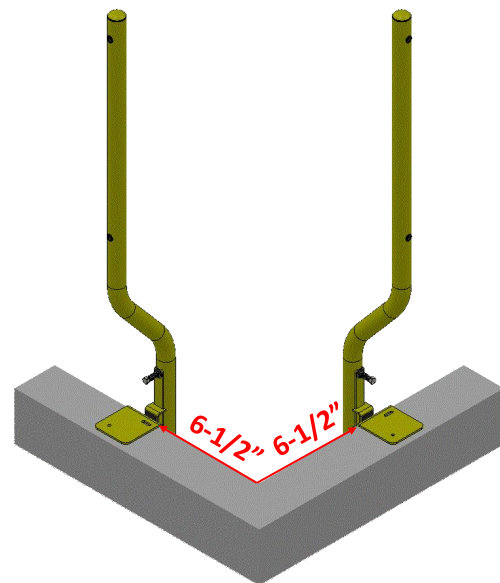

Figure 1.4
(INSIDE CORNER)

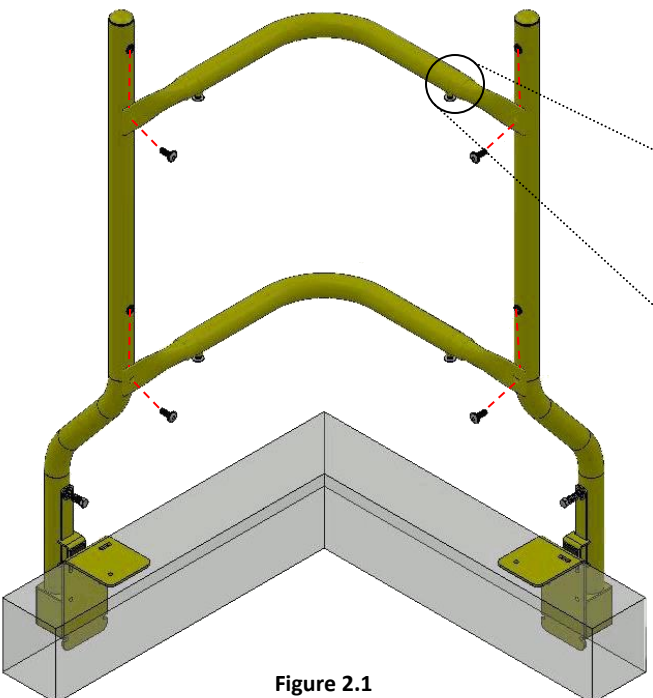

Figure 2.1

STEP 2—Attach the Corner Railings by loosely fastening 3/8"-16 X 1" Button-Head Screws DO NOT FULLY TIGHTEN YET. (see Figure 2.1). 3/8"-16 X 3/4" Button-Head Screws on Adjustable Corners can be tightened to permanently set the adjustable length. (see Figure 2.2)

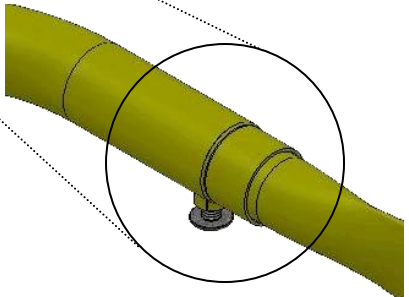

Figure 2.2

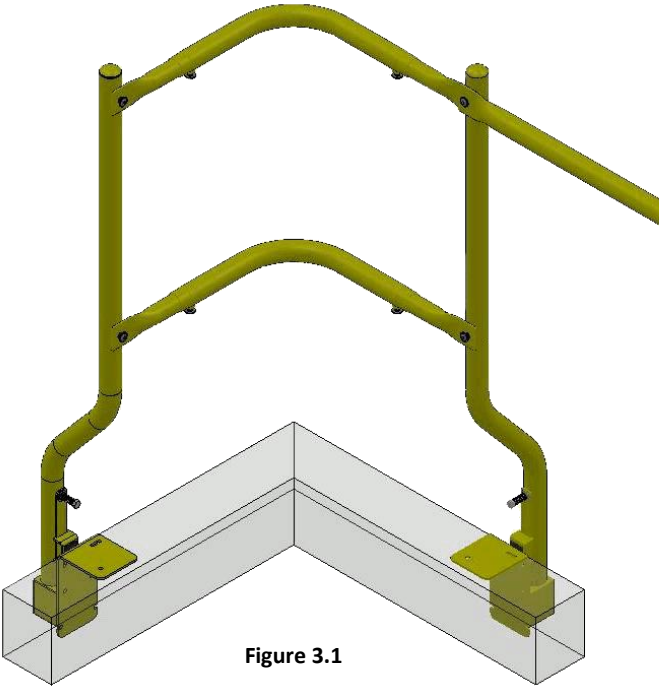
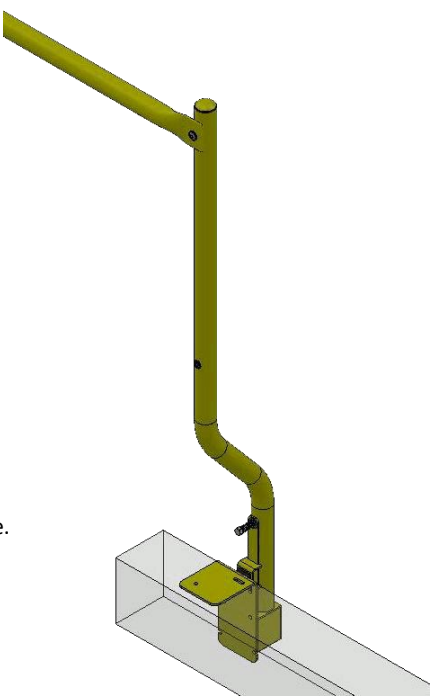

Figure 3.1

STEP 3—Install uprights using the fixed length horizontal rails as a guide. Unfasten one end of the adjustable corner from the previous step and reattach both the corner and a fixed length railing. Attach the opposite end of the fixed length rail to the next upright to be installed; plumb the upright and attach upright as shown in **STEP 1**
*****Note—Always install railing with weep holes facing down.**



STEP 4— Continue adding uprights from both corners using the method described in **STEP 3**, working toward the middle of the run. *The second horizontal rail may also be installed during this process or added after all posts are installed.* An adjustable length rail is provided to complete the middle section of guardrail.

In some cases, where two corners do not exist and the guardrail will stop at a wall, for example; the adjustable rail can be placed at the end opposite of the corner to allow for final length adjustment.

Adjustable rails can allow for expansion of the system. To use the adjustable railing as an expansion joint, do not tighten the set screw (see **Figure 4.1**). To permanently lock the adjustable rail to a fixed length, tighten the set screw.

*****Note**— Always install railing with set screw facing down.

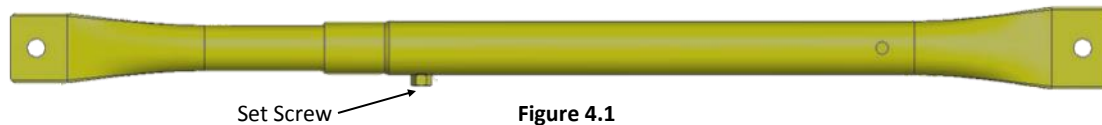

STEP 5— Install Corner Rail Supports by removing 3/8"-16 x 1" Button-Head Screws and replacing with 3/8"-16 x 1 1/2" Button-Head Screws.

TIP— Corner Rail Supports are directional with one side to fit 1 3/8" railing and the other 1 5/8" railing.

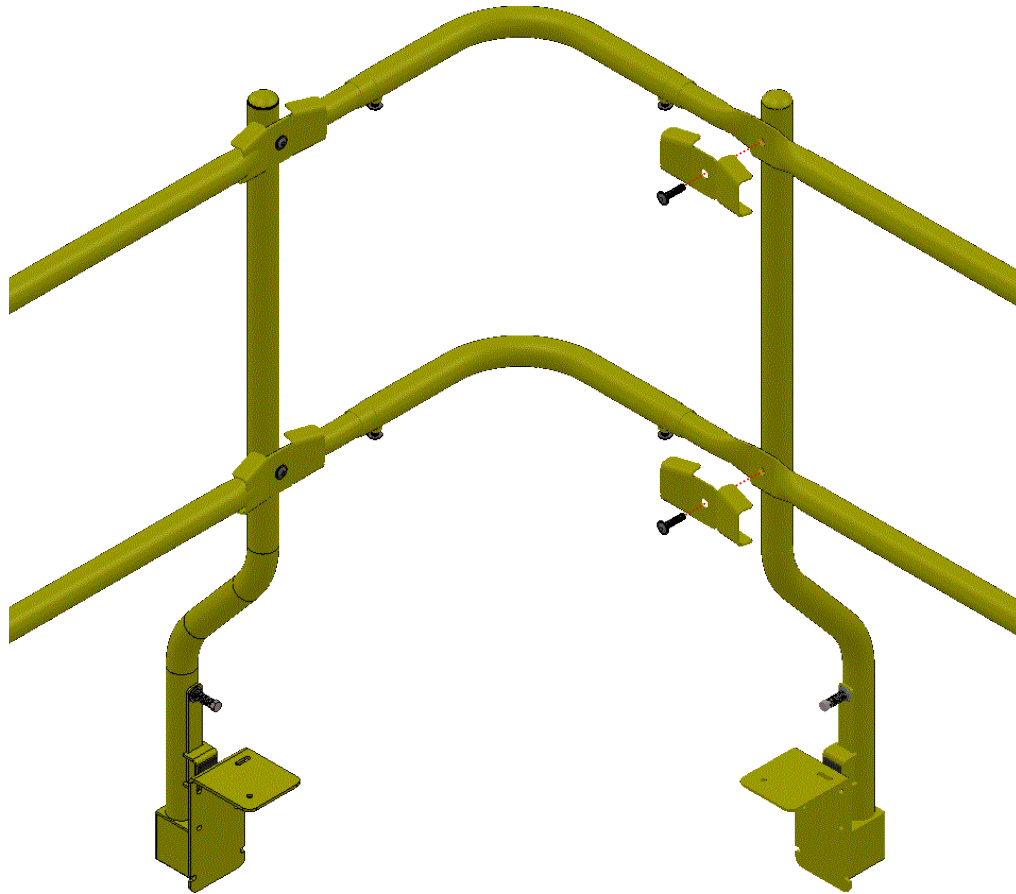

STEP 6— Tighten all 3/8"-16 Button-Head Screws for horizontal rails to the recommended torque of 70 (seventy) inch pounds for clean and dry bolts.

STEP 7— Continue the processes in **STEPS 1 - 6** until the guardrail system is complete.

INSTALLATION OF ROOFING MEMBRANE & SHEET METAL

STEP 8—Installation of roofing membranes and sheet metal can begin after proper installation of the Permanet Guardrail has been completed following the instructions outlined in **STEPS 1 - 7**.

STEP 9— Roofing membranes should be installed over the top of the Permanet mounting bracket and extend a minimum of 1” (one inch) below wood nailer assembly or per roofing manufacturer or specification guidelines.

STEP 10—Rotate Spacer Blocks on the uprights upward and out of the way to allow installation of the sheet metal detail (see **Figure 10.1**).

STEP 11—Install continuous sheet metal cleat directly over the top of the mounting bracket on the Upright Assembly. Continuous cleat should be fabricated and installed per SMACNA, manufacturer or project specification guidelines.

STEP 12— Install sheet metal component over continuous cleat and install per SMACNA, manufacturer or project specification guidelines.

STEP 13—Rotate Spacer Block to the down position. Spacer block may sit firmly against the sheet metal or have a minimal gap. (see **Figure 5.1**)

*****Note— The Spacer Block bolt assembly does not need to be fully tight and is typically set correctly from the factory.**

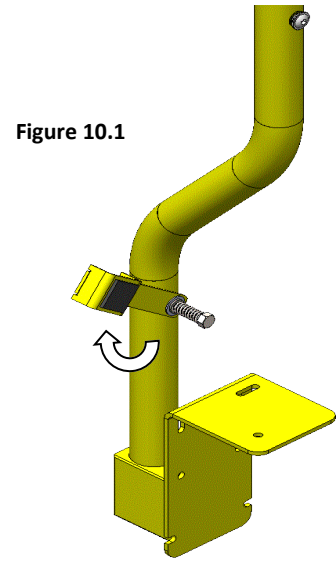
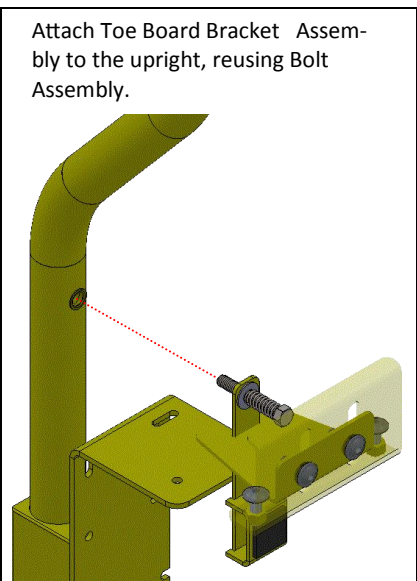
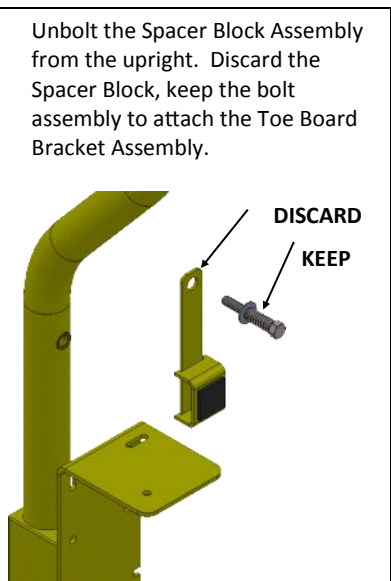
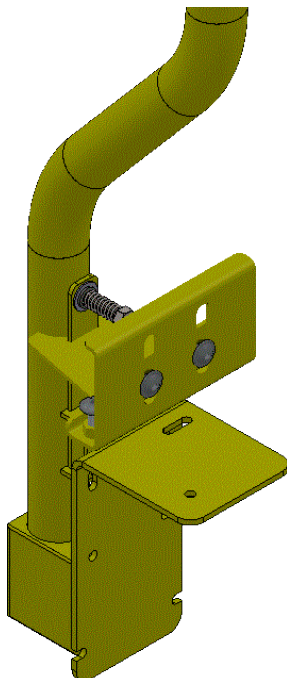

Figure 10.1

OPTIONAL TOE BOARD INSTALLATION

If optional Toe Boards were ordered for the system, the Toe Board Brackets are pre-installed on the Uprights from the factory.

If optional Toe Boards were ordered after the initial installation, the Toe Board Brackets can easily be retrofit following the instructions below.



Unbolt the Spacer Block Assembly from the upright. Discard the Spacer Block, keep the bolt assembly to attach the Toe Board Bracket Assembly.

Attach Toe Board Bracket Assembly to the upright, reusing Bolt Assembly.

OPTIONAL INTEGRATED LIGHTNING PROTECTION

STEP 1— Place Aluminum Upright Cap (A867) over Permanet Upright, matching A867 slot to Upright Insert Rivet Nut.

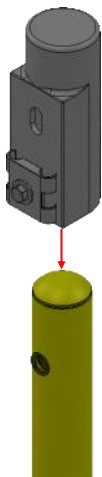

STEP 2— Attach Aluminum Rail Connector (A861) to aluminum railing tube. Tighten set screw to lock Rail Connector in place.

TIP— Cut tube as needed to match adjustable railing lengths.

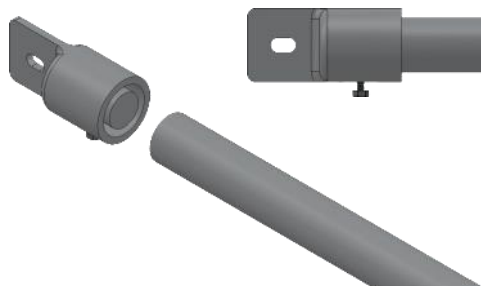

STEP 3— Attach Aluminum Corner Assemblies and Aluminum Rail Assemblies thru slots in Upright Caps and to Uprights using 3/8" - 16 x 1 1/2" Screws.

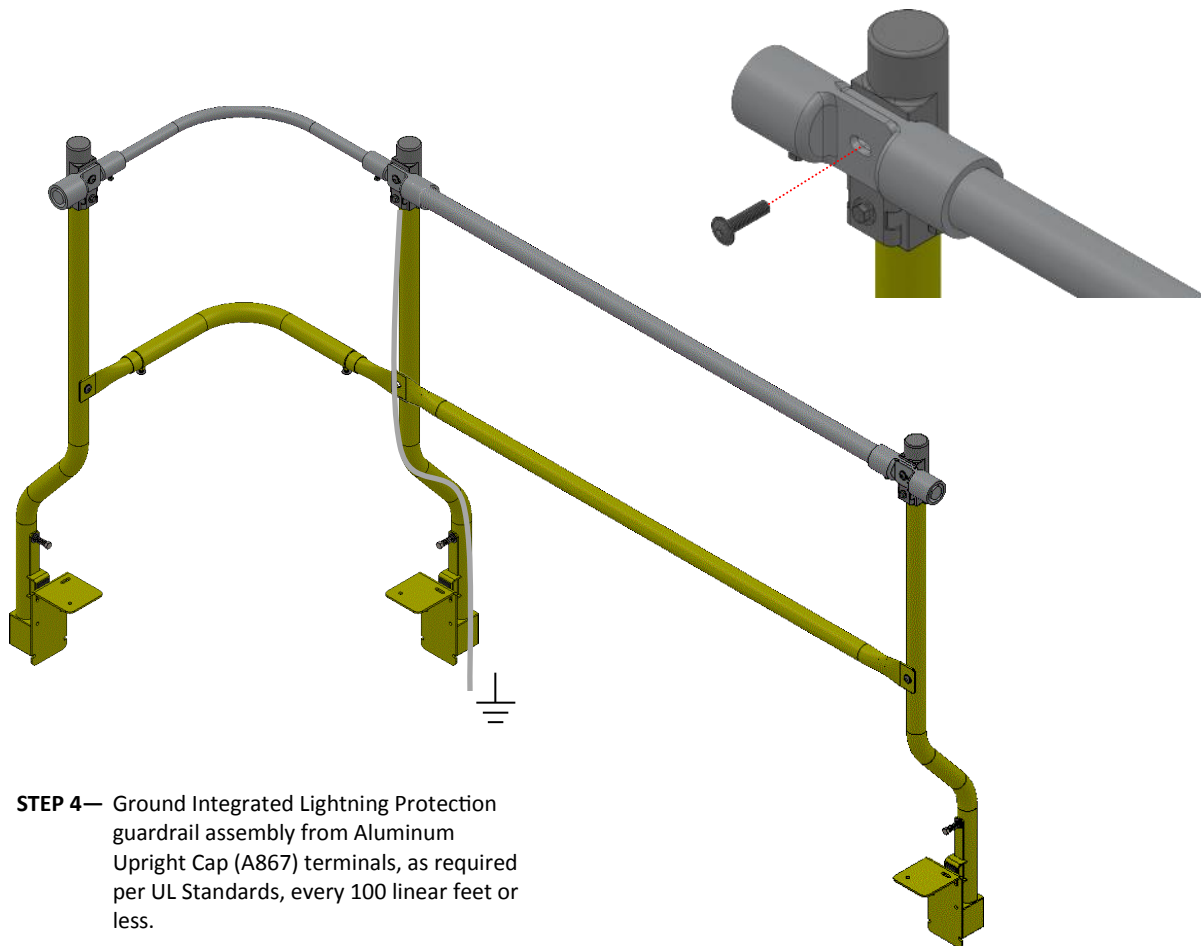

STEP 4— Ground Integrated Lightning Protection guardrail assembly from Aluminum Upright Cap (A867) terminals, as required per UL Standards, every 100 linear feet or less.

APPLICATIONS

The Permanet Guardrail is to be used as a guardrail system for roofs as described by OSHA Standard 1910.29 and 2012 International Building Code.

The Permanet Guardrail should be used as a part of a complete fall protection system plan.

USE AND LIMITATIONS

The Permanet Guardrail can be used with many different types of roofing, decking, edge, or parapet conditions provided a competent professional has determined that the roof, deck, edge and/or structure is capable of withstanding the load requirements of the specified system.

The Permanet Guardrail is intended for use as a guardrail system as defined by OSHA and meets and exceeds the requirements set for by OSHA Standard 1910.29 and 2012 International Building Codes when properly installed.

NO component of the Permanet Guardrail has been designed as an '*Anchorage*' point and should NEVER be used as such.

Hoisting and snap hook devices should never be attached to any component of the Permanet Guardrail.

Leading Edge Safety guardrail systems are designed to prevent employees from falling. While companies can provide safety training and safety systems, such as guardrail systems, every employee is responsible for their own safety and should act in a safe and responsible manner while on any roof.

In addition to fall protection such as guardrails, Leading Edge Safety recommends implementing a Fall Protection Plan for every roof and safety training in accordance with OSHA Standards.

Improper use of Leading Edge Safety guardrail systems can result in serious injury or death.

AFTER A FALL OR IMPACT

All components that have been subjected to fall or impact forces must be removed from service immediately for inspection and replacement if necessary by competent personnel.

BEFORE EACH USE

Guardrail systems should be inspected prior to each use for wear, damage or deterioration, and defective components shall be removed from service.

INSPECTION STEPS

STEP 1: Check for loose, bent or damaged parts.

STEP 2: Check fasteners/connectors for distortion, cracks, or other damage and proper torque.

STEP 3: All labels must be present and fully legible.

STEP 4: Check for corrosion on Parts.

MAINTENANCE AND CARE:

- A. Inspect all guardrail components before each use.
- B. Annually and before each use, inspect all fasteners for proper torque.
- C. Maintain paint finish to prevent corrosion.
- D. Replace damaged or deteriorated parts immediately.