

GE98SH

QTY	MODEL	WIDTH	LENGTH	FINISH	LOCATION

B

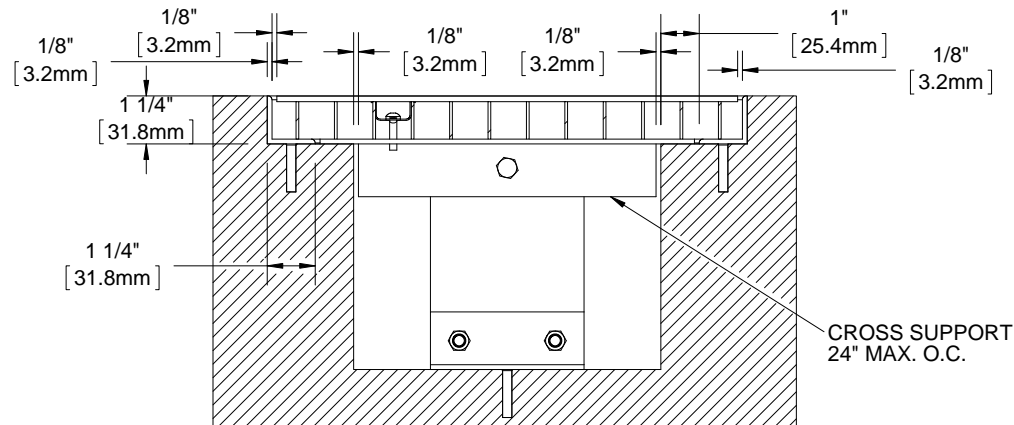
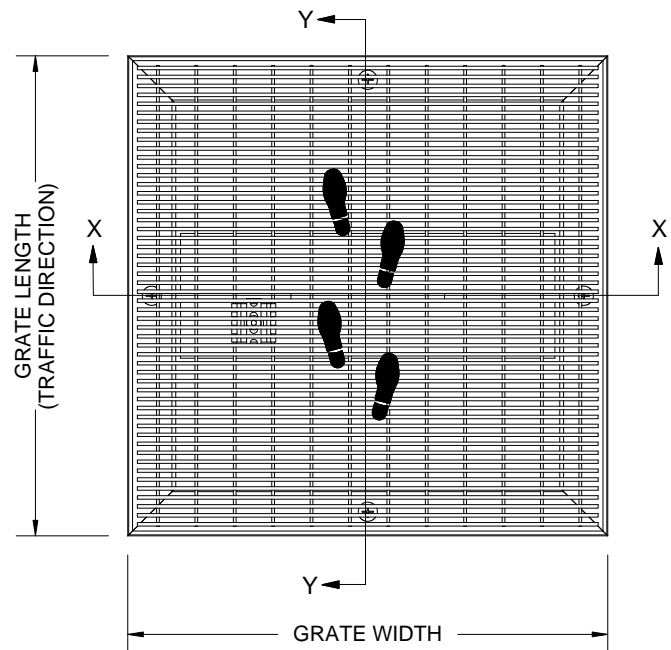

SECTION X-X

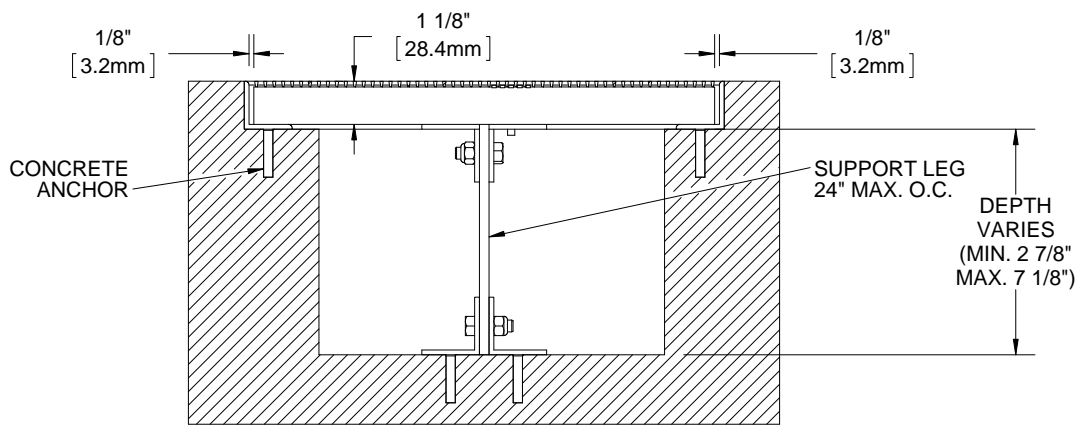

SECTION Y-Y

- NOTES:**
- FRAME ANCHOR SPACING: 6" FROM CORNERS, 24" MAX
 - ALL STAINLESS STEEL FRAME CORNERS ARE WELDED
 - ALL RAIL COMPONENTS ARE MADE OF TYPE 304 STAINLESS STEEL, ALL FRAME COMPONENTS ARE MADE OF TYPE 304 STAINLESS STEEL, ALL CROSS SUPPORTS ARE MADE OF ALUMINUM.
 - FOR MAXIMUM STRENGTH, EACH JOINT BETWEEN SURFACE WIRES AND SUPPORT RODS SHALL BE RESISTANCE WELDED. BECAUSE OF THE MANUFACTURING PROCESS USED TO DO THIS, THE SURFACE WIRES AND SUPPORT RODS ARE NOT PERPENDICULAR, AND THE WIRES AND RODS OF ADJACENT SECTIONS WILL NOT BE ALIGNED.
 - GRATE IS MADE WITH .090" X .150" (2.4mm X 4.0mm) STAINLESS STEEL WIRE SPACED .235 (5.9mm) O.C. AND WELDED SUPPORT RODS SPACED 1" (25.4mm) O.C.
 - TREAD WIRE MUST RUN PERPENDICULAR TO TRAFFIC DIRECTION
 - ADDITIONAL INFORMATION CAN BE FOUND IN THE PRODUCT SPECIFICATION AND IS CONSIDERED PART OF THIS TRANSMITTAL.
 - FRAME MODEL NUMBER: FE98HDAM

PROJECT:			
ARCHITECT:			
CONTRACTOR:			
<p>9300 73rd Avenue North Minneapolis, MN 55428</p>		DESCRIPTION:	
		eleGRIL®, 9/8", Stainless Steel Grate with Adjustable Deep Pit Frame	
NAME	DATE	SIZE	DWG. NO.
DRAWN DKL	4/17/15	A	GE98SH-FDAM
RELEASED PE	4/17/15	SCALE: NTS	SHEET 1 OF 1
			REV B

PROPRIETARY AND CONFIDENTIAL: THE INFORMATION CONTAINED IN THIS DRAWING IS THE SOLE PROPERTY OF NYSTROM. ANY REPRODUCTION IN PART OR AS A WHOLE WITHOUT THE WRITTEN PERMISSION OF NYSTROM IS PROHIBITED.