

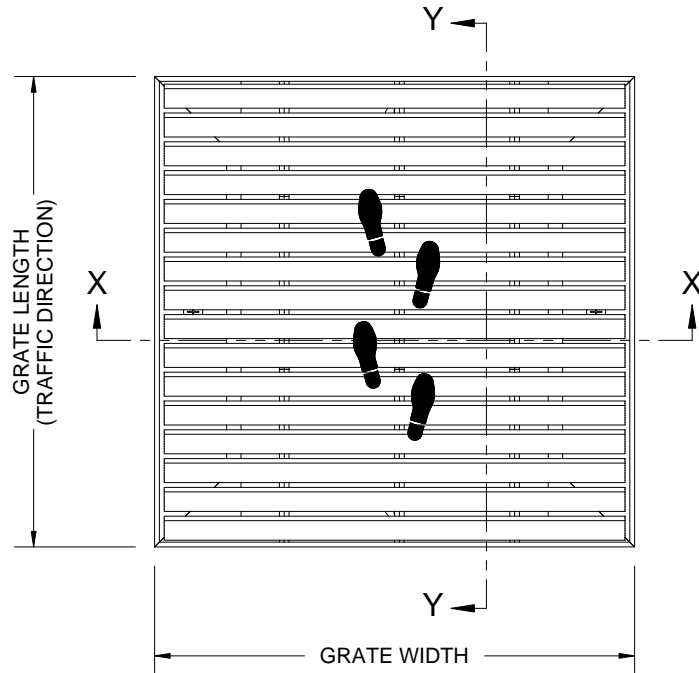

GD74L
SERRATED
ALUMINUM
THINLINE

QTY	MODEL	WIDTH	LENGTH	FINISH	LOCATION

B



B

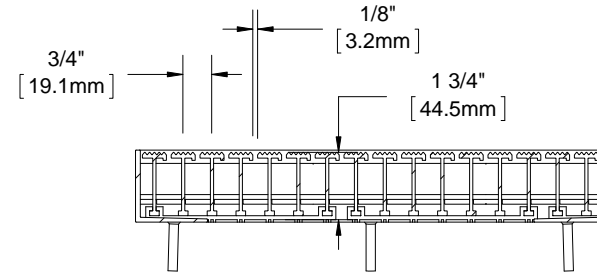

SECTION Y-Y

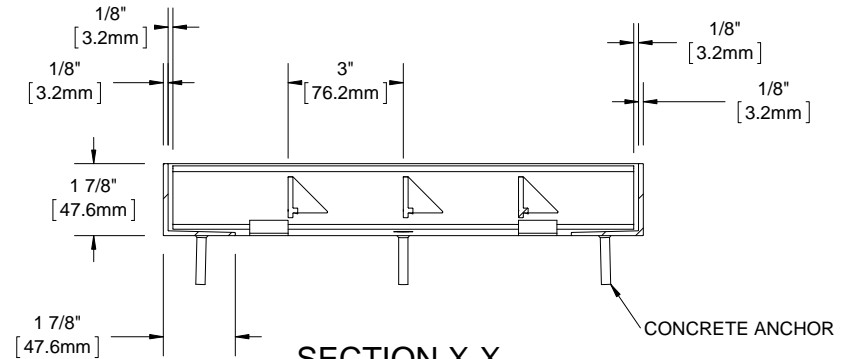

SECTION X-X

A

A

NOTES:

- STANDARD MAXIMUM SECTION SIZE OF GRATE WIDTH NOT TO EXCEED 8'-0", CUSTOM SECTIONING AVAILABLE
- FRAME ANCHOR SPACING: 6" FROM CORNERS, 24" MAX
- VERIFY TRAFFIC DIRECTION AND THAT SECTIONING DOES NOT OCCUR IN A TRAFFIC LANE
- ALL RAIL COMPONENTS ARE MADE OF 6063-T6 ALUMINUM ALLOY, ALL FRAME COMPONENTS ARE MADE OF 6063-T5 ALUMINUM ALLOY. KEYLOCKS ARE MADE WITH 6061-T6 ALUMINUM ALLOY
- TREAD RAILS MUST RUN PERPENDICULAR TO TRAFFIC DIRECTION
- TRAFFIC DIRECTION DIMENSION CAN ONLY BE CHANGE IN 3/4" (19.1 MM) INCREMENTS UNLESS OPTIONAL ALUMINUM FILLER IS INCLUDED
- GRATE DIMENSION ALLOWS FOR CLEARANCE BETWEEN GRATE SECTIONS AND FRAMES IN THE WIDTH DIMENSION
- ADDITIONAL INFORMATION CAN BE FOUND IN THE PRODUCT SPECIFICATION AND IS CONSIDERED PART OF THIS TRANSMITTAL.
- FRAME MODEL NUMBER: FD74LBM

PROJECT:

ARCHITECT:

CONTRACTOR:



9300 73rd Avenue North
Minneapolis, MN 55428

DESCRIPTION:

GRATEdesign®, 1-3/4", Aluminum, Grate with
Mechanically Fastened, Aluminum Frame

NAME	DATE	SIZE	DWG NO.
DRAWN DKL	5/8/15	A	GD74L-FLBM
RELEASED PE	5/8/15	SCALE: NTS	SHEET 1 OF 1
			REV B

PROPRIETARY AND CONFIDENTIAL: THE INFORMATION CONTAINED IN THIS DRAWING IS THE SOLE PROPERTY OF NYSTROM. ANY REPRODUCTION IN PART OR AS A WHOLE WITHOUT THE WRITTEN PERMISSION OF NYSTROM IS PROHIBITED.