

GL10W

QTY.	MODEL	WIDTH	LENGTH	LOCATION

RECESS OPENING DIMENSIONS:

\_\_\_\_\_ WIDTH X \_\_\_\_\_ LENGTH

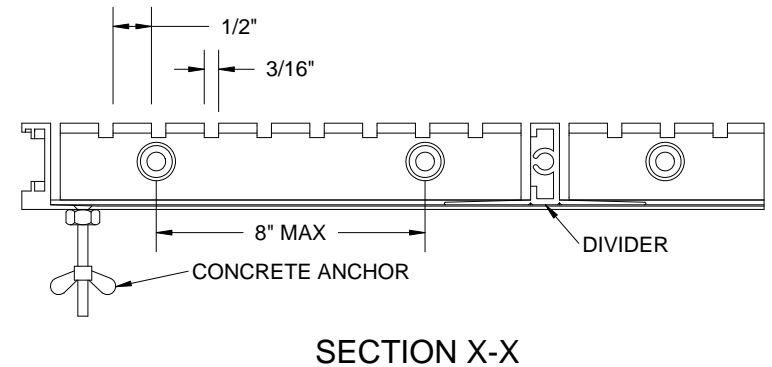
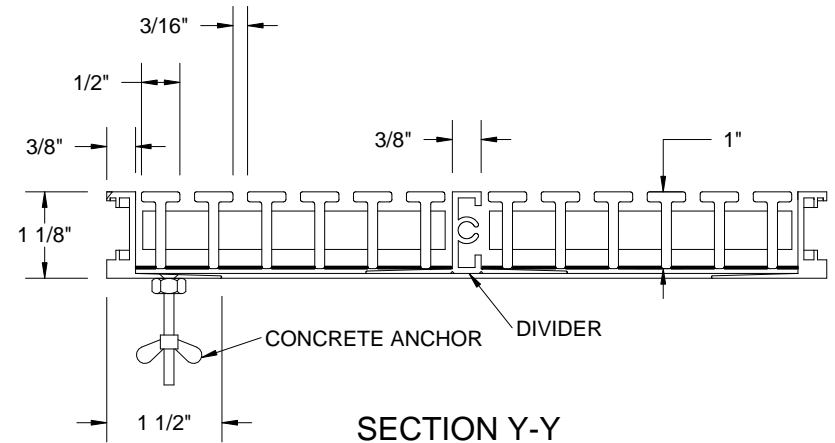
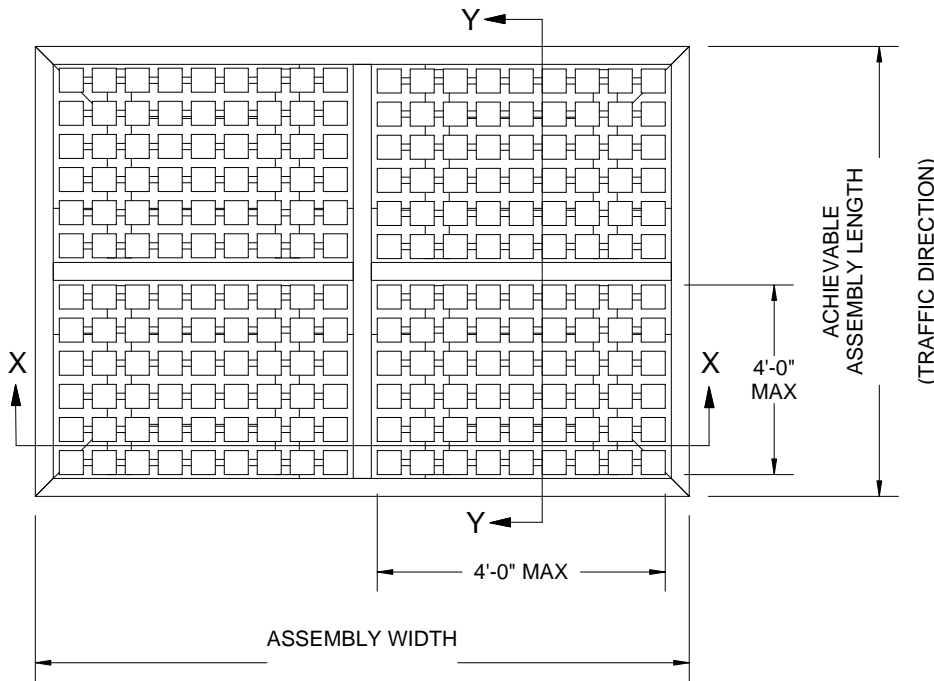

- NOTES:
- MAXIMUM GRATE SECTION SIZE NOT TO EXCEED 48" X 48"
  - GRATE MUST BE INSTALLED IN A LEVEL BED RECESS
  - RAILS ARE 6061-T6 ALUMINUM ALLOY; FRAMES ARE 6063-T6 ALUMINUM ALLOY
  - TREAD RAILS MUST RUN PERPENDICULAR TO TRAFFIC DIRECTION
  - DESIGN CLEARANCE BETWEEN GRATE AND FRAME IS 1/8"
  - ACTUAL ACHIEVEABLE GRATE LENGTH IS DEPENDANT ON BOTH NUMBER AND SIZE OF SECTIONS
  - SITE OPENING LENGTH MUST BE ADJUSTED TO GRATE AND FRAME ACHIEVEABLE LENGTH
  - ADDITIONAL INFORMATION CAN BE FOUND IN THE PRODUCT SPECIFICATION AND IS CONSIDERED PART OF THIS TRANSMITTAL

PROJECT:			
ARCHITECT:			
CONTRACTOR:			
QTY:		<b>GL10W</b>	
PART#:		<b>FL10LBC</b>	
<p>9300 73rd Avenue North Minneapolis, MN 55428</p>		TITLE: AlumaGRIL Grate Level Bed Cast In Frame Waffle Cut Grate	
NAME	DATE	SIZE	DWG. NO.
DRAWN	DKL	01/12/18	A
RELEASED	DT	01/12/18	WEIGHT:
Nystrom EFS GL10W-LBC ShpDr			REV A