

**Expansion Joint Systems
Series: EJ-NBR-W**

Prepare for Installation

1. Locate the packing slip(s) and shop drawings.
2. Verify that all products listed on the packing slip are included in the package.
3. Check the products for damage. If products are damaged, report a freight claim immediately and leave the products in their packaging. If you sign for products without reporting damage you waive your right to a freight claim and will be responsible for their replacement cost.
4. Read the instructions thoroughly before beginning installation.

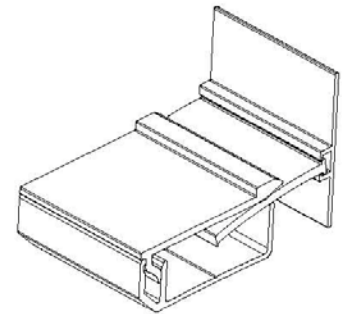

Tools List:

- Drill
- Level
- Rubber Mallet
- Chalk Line
- Chop Saw

Parts List:

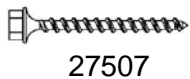

¼ Dia X 1 ¾ Long
Masonry Screw

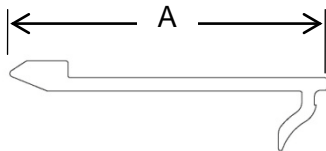

Top Plate	"A"	P/N
EJ-NBR-100W	2.377	29477
EJ-NBR-200W	3.377	29479

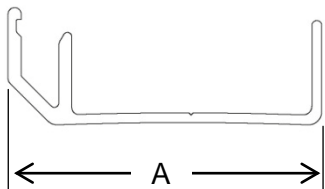

Bottom Plate	"A"	P/N
EJ-NBR-100W	2.25	29478
EJ-NBR-200W	3.25	29480

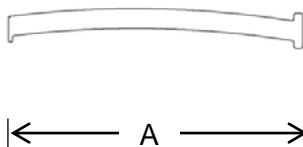

Center Plate	"A"	P/N
EJ-NBR-100W	1.85	29487
EJ-NBR-200W	3.60	29489



Wall Plate	"A"	P/N
EJ-NBW-100W	2.125	29485
EJ-NBW-200W	2.125	29485

Installation:

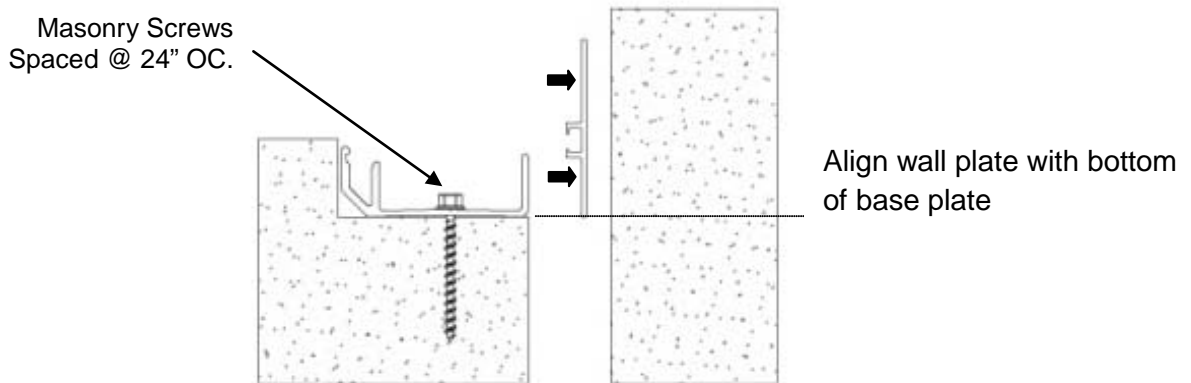

1. If required, fire barrier and/or moisture barrier should be installed at this time.
2. Snap level line on wall even to height of block-out surface. Wall plate to be attached level to line using appropriate anchor (by others).
3. Pre-drill thru-holes in bottom plate for supplied masonry screws. Position the base extrusion flush with the inside surface of the joint opening. (Allow 1/8 – 1/4 inch gap between each base plate for thermal expansion end to end). Use base plate as template to mark hole locations. Field drill holes thru the base plate. Attach base plate to floor surface.

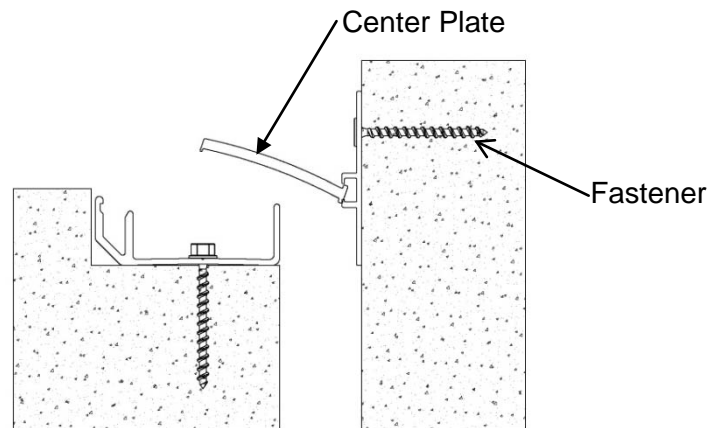

4. Slide center plate into wall plate as shown, and drop down to base plate.

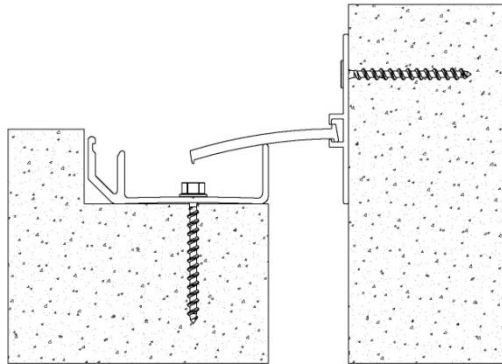

5. Place center slide plate into position against the adjacent base plate.

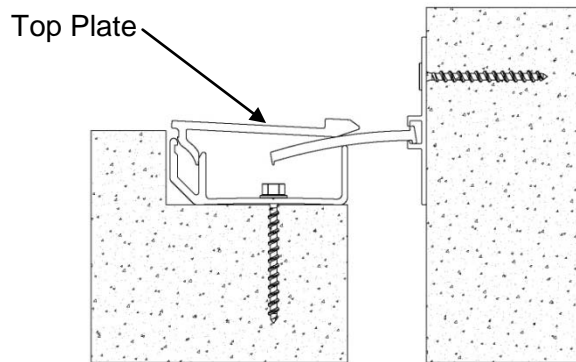

6. Align aluminum top plate in front of bottom plate as shown. Walk along top plate to snap into place. If required, complete installation with lightly taping top plate into bottom plate with rubber mallet. It should click into place all along the length of the top plate. When installing, exercise care not to damage top plate.

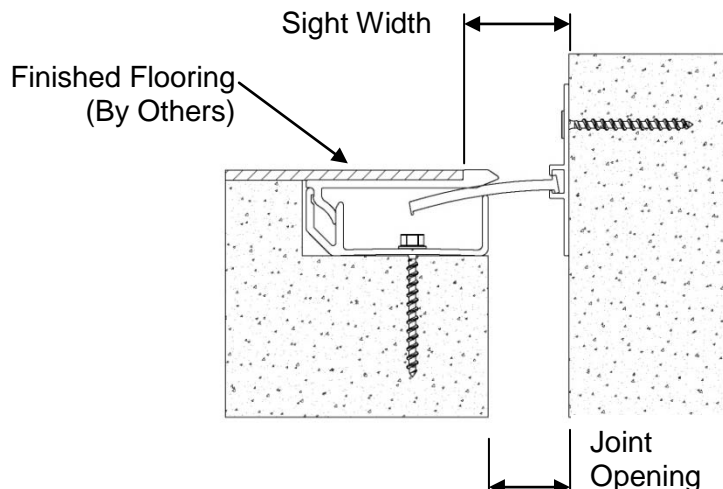



Right to site.

IO&M

Expansion Joint Systems – 07 95 13

Operation:

Expansion joints are designed and built for years of dependable service.

Maintenance:

1. Expansion Joints should be cleaned routinely.
2. Exposed surfaces can be cleaned with a mild water-based cleaning solution. Wipe clean with a sponge or soft cloth.
3. Do not use steel wool or powdered abrasive cleaners as they will scratch the aluminum surface.
4. If any questions arise during the operation or maintenance of the products, please feel free to call our toll-free number for assistance, 1-800-547-2635 for technical support.