

SPECIFICATIONS:

- ① **COVER:** 11 GA ALUM COVER STIFFENED TO WITHSTAND A LIVE LOAD OF 40PSF WITH A MAX DEFLECTION OF 1/150 OF THE SPAN
- ② **LINER:** 18 GA ALUM
- ③ **CURB AND COUNTERFLASH W/ EZ TAB:** 11 GA ALUM
- 4 **FINISH:** MILL FINISH
- ⑤ **SPRING/HINGE ASSEMBLY:** ZINC PLATED STEEL TAMPER-PROOF HINGE CONTAINED WITHIN SPRING/HINGE ASSEMBLY. TELESCOPIC TUBES CONTAIN COIL STEEL COMPRESSION SPRINGS FOR LIFT ASSISTANCE
- ⑥ **HOLD OPEN ARM:** LOCKS COVER IN FULLY OPEN POSITION - ZINC PLATED STEEL WITH RED POLYPROPYLENE GRIP HANDLE PULL RELEASE
- ⑦ **LATCH:** 2 POINT ROTARY LATCH HOLDS COVER CLOSED AGAINST WIND UPLIFT. INTERNAL AND EXTERNAL TURN HANDLES WITH PADLOCK HASPS

- ⑧ **INSULATION:** 1" POLYISO (R6) CURB, 1" POLYSTYRENE (R4) COVER
- ⑨ **GASKET:** ADHESIVE BACKED EPDM RUBBER EXTRUSION
- 10 **SIZING:** WIDTH X LENGTH DIMENSIONS ARE MEASURED INSIDE CURB TO INSIDE CURB WHERE THE WIDTH IS HINGE TO LATCH AND LENGTH IS HINGED SIDE WITH SPRINGS

ROOF HATCH SIZE 30" (WIDTH) x 96" (LENGTH)
CLEAR OPENING 21.94" (WIDTH) x 94.31" (LENGTH)
ROUGH OPENING 30" (WIDTH) x 96" (LENGTH)

PROPRIETARY AND CONFIDENTIAL: THE INFORMATION CONTAINED IN THIS DRAWING IS THE SOLE PROPERTY OF NYSTROM. ANY REPRODUCTION IN PART OR AS A WHOLE WITHOUT THE WRITTEN PERMISSION OF NYSTROM IS PROHIBITED.

PROJECT:			
ARCHITECT:			
CONTRACTOR:			
QTY:			
PART#:		RHHA30X96S1T	
 9300 73rd Avenue North, Minneapolis, MN 55428		TITLE:	
		Roof Hatch, Hurricane, 30x96, Sngl Dr, Zinc Hdw, Alum, Mill, Sngl Wall Curb	
NAME	DATE	SIZE	DWG. NO.
DRAWN	SJB	11/5/15	A
RELEASED	-	-	WEIGHT: 190.7
REV			A
RHHA30X96S1T			SHEET 1 OF 2

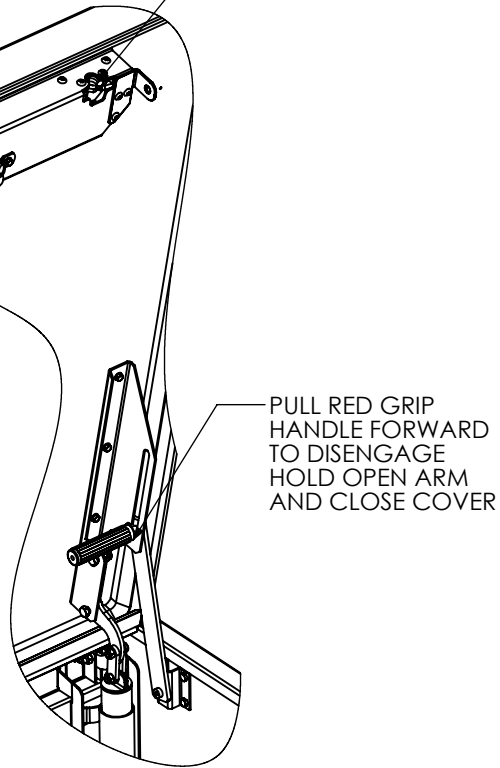
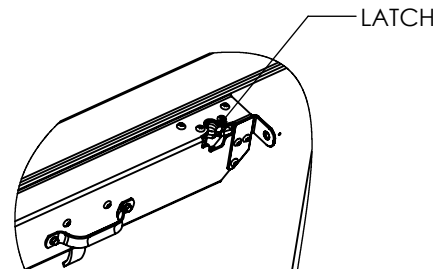
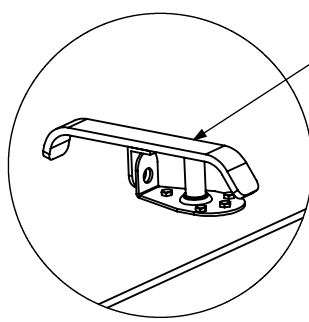
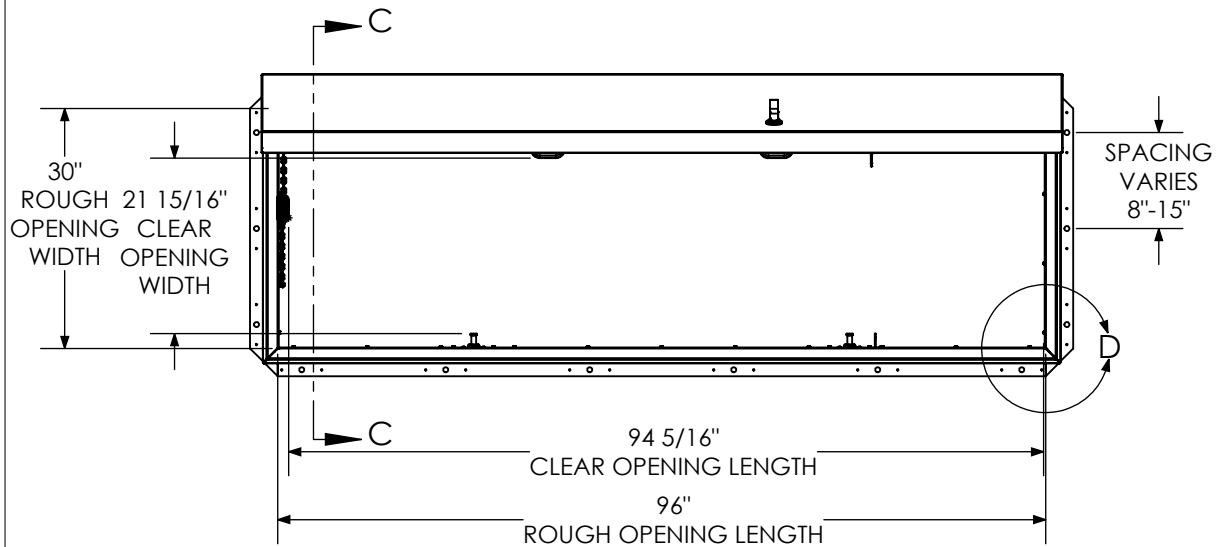

HARDWARE DETAILS

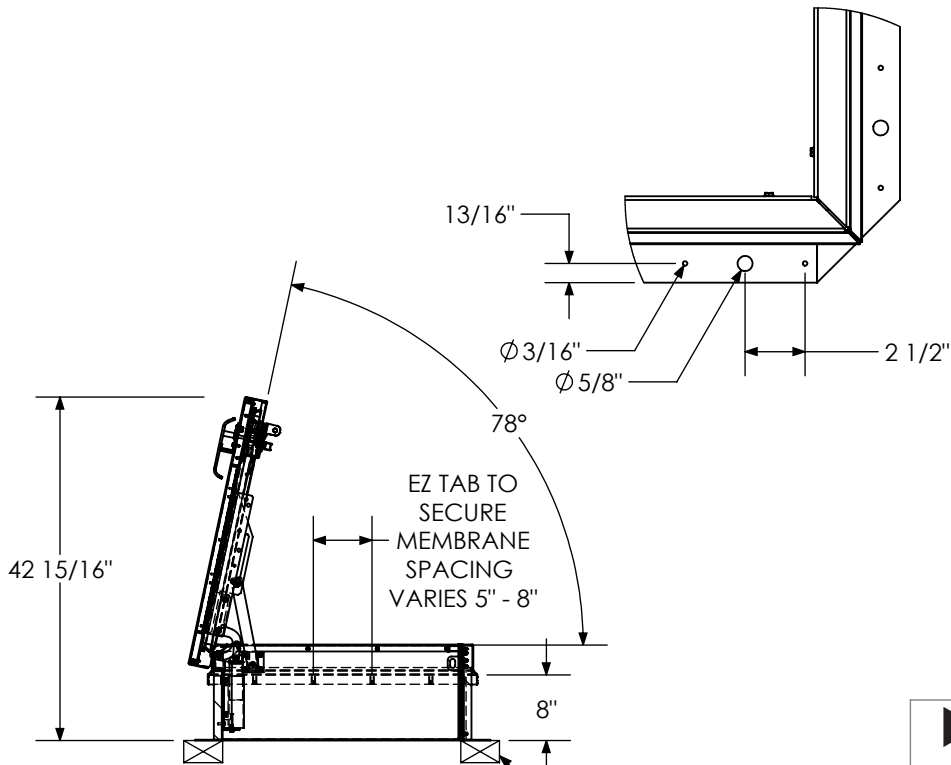

SECTION C-C

WOOD, CONCRETE, OTHER MATERIAL FOR MOUNTING BY OTHERS (NIC) PROPRIETARY

AND CONFIDENTIAL: THE INFORMATION CONTAINED IN THIS DRAWING IS THE SOLE PROPERTY OF NYSTROM. ANY REPRODUCTION IN PART OR AS A WHOLE WITHOUT THE WRITTEN PERMISSION OF NYSTROM IS PROHIBITED.

			TITLE: Roof Hatch, Hurricane		
9300 73rd Avenue North, Minneapolis, MN 55428			30x96, Sngl Dr, Zinc Hdw, Alum, Mill, Sngl Wall Curb		
NAME	DATE	SIZE	DWG. NO.	REV	
SJB	11/5/15	A	RHHA30X96S1T	A	
RELEASED	-	-	WEIGHT: 190.7	SHEET 2 OF 2	