

SPECIFICATIONS:

- ① **COVER:** 11 GA (.090)ALUMINUM ,STIFFENED TO WITHSTAND A LIVE LOAD OF 40PSF WITH A MAX DEFLECTION OF 1/150 OF THE SPAN.
- ② **CURB:** 11 GA (.090)ALUMINUM CURB COUNTERFLASH WITH EZ TABS.
- ③ **FINISH:** MILL
- ④ **INSULATION:** 1" POLYISO R-6 (5.6 LTR) IN CURB, 1" POLYSTYRENE R-4 (3.8 LTR) IN COVER.
- ⑤ **GASKET:** EXTRUDED EPDM RUBBER ADHESIVE BACKED GASKET SEAL CONTINUOUS AROUND COVER.
- ⑥ **SPRING:** GAS SPRING WITH DAMPER FOR SMOOTH, CONTROLLED, COUNTERBALANCED LIFT ASSISTANCE.
- ⑦ **HINGE:** PINTLE HINGE WITH STAINLESS STEEL HINGE PINS.
- ⑧ **HOLD OPEN ARM:** ZINC PLATED STEEL AUTOMATIC HOLD OPEN ARM LOCKS COVER IN FULLY OPEN POSITION WITH REPOLYPROPYLENYL GRIP HANDLE PULL RELEASE.

- ⑨ **LATCH:** ZINC PLATED STEEL SLAM LATCH, HOLDS COVER CLOSED AGAINST WIND UPLIFT, INTERIOR AND EXTERIOR TURN HANDLES WITH PADLOCK HASPS.
- ⑩ **PULL HANDLE:** INTERIOR PULL DOWN HANDLE, SAFETY YELLOW POWDER COAT

NOTES:

-WHEN INSTALLING ON A PITCHED ROOF UP TO 7:12, THE HINGE SIDE(LENGTH)MUST BE PARALLEL TO THE SLOPE.
 - WIDTH X LENGTH DIMENSIONS ARE MEASURED INSIDE CURB TO INSIDE CURB. THE WIDTH IS HINGE TO LATCH AND LENGTH IS HINGED SIDE.

ROOF HATCH SIZE 48" (WIDTH) x 48" (LENGTH)
CLEAR OPENING 37 3/4"(WIDTH) x 47 1/2" (LENGTH)
ROUGH OPENING 48" (WIDTH) x 48" (LENGTH)

PROPRIETARY AND CONFIDENTIAL: THE INFORMATION CONTAINED IN THIS DRAWING IS THE SOLE PROPERTY OF NYSTROM. ANY REPRODUCTION IN PART OR AS A WHOLE WITHOUT THE WRITTEN PERMISSION OF NYSTROM IS PROHIBITED.

PROJECT:		
ARCHITECT:		
CONTRACTOR:		
QTY:		
PART:		RHHA48X48S1T
nystrom		TITLE: Roof Hatch, Hurricane
9300 73rd Avenue North, Minneapolis, MN 55428		48x48, Sngl Dr, Alum, Mill, Sngl Wall Curb
NAME	DATE	SIZE DWG. NO.
DRAWN SGS	04/01/15	A RHHA48X48 S1T
RELEASED IMT	04/01/15	WEIGHT: 107.5 lbs
		REV -
		SHEET 1 OF 2

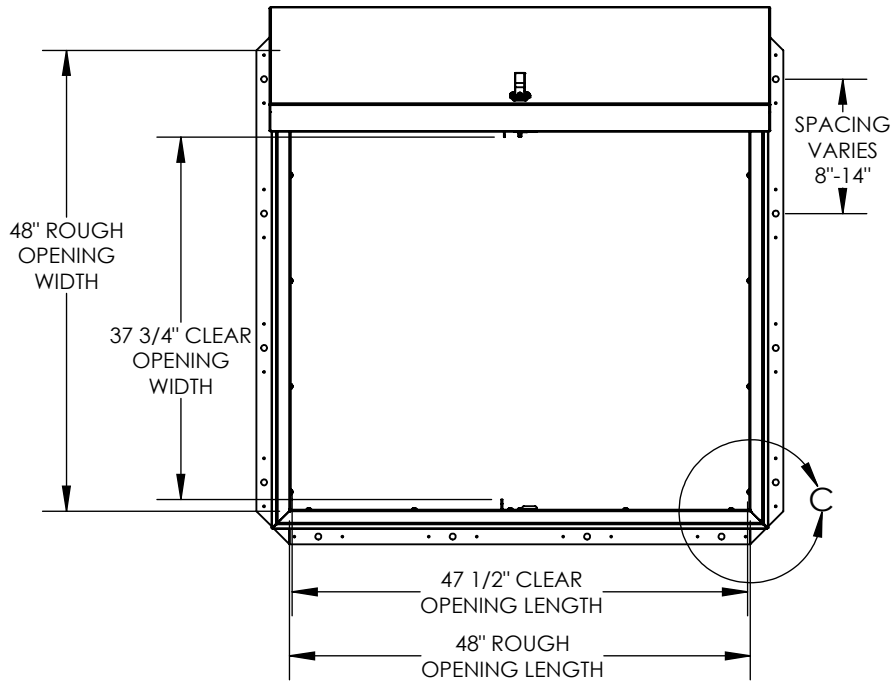

INTERNAL
PADLOCK HASP
SLAM LATCH
PULL HANDLE

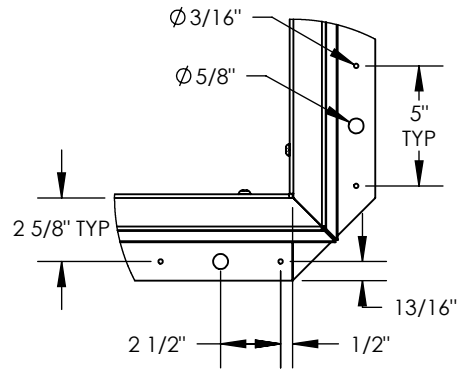

DETAIL C
SCALE 1 : 8

PULL TO RELEASE
HOLD OPEN ARM.

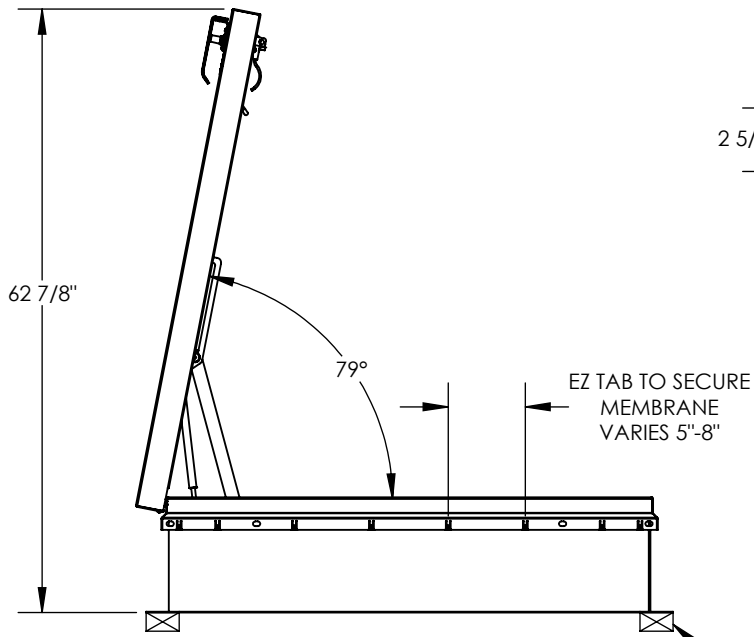

WOOD, CONCRETE, OTHER
MATERIAL FOR MOUNTING
BY OTHERS (NIC)

			TITLE:		
9300 73rd Avenue North, Minneapolis, MN 55428			Roof Hatch, Hurricane 48x48, Sngl Dr, Alum, Mill, Sngl Wall Curb		
NAME	DATE	SIZE	DWG. NO.	REV	
DRAWN SGS	04/01/15	A	RHHA48X48S1T	-	
RELEASED IMT	04/01/15	WEIGHT: 107.5 lbs	SHEET 2 OF 2		