

B

B

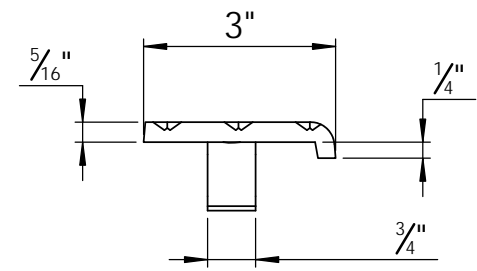
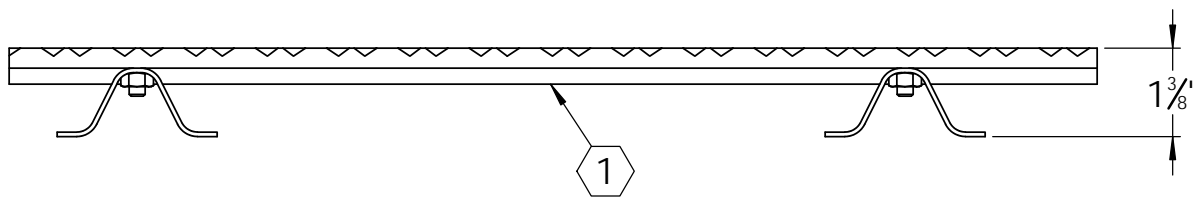
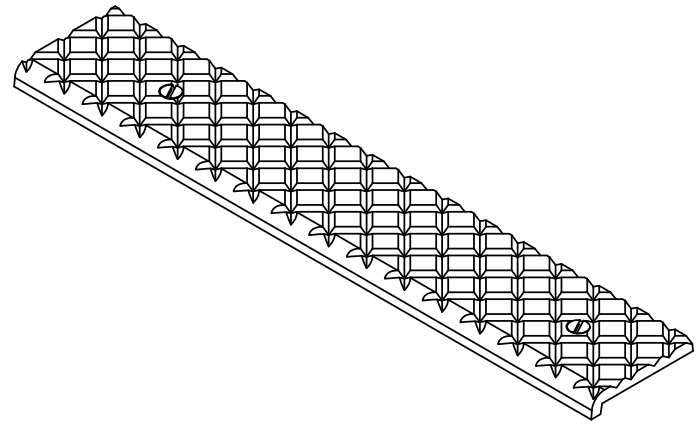
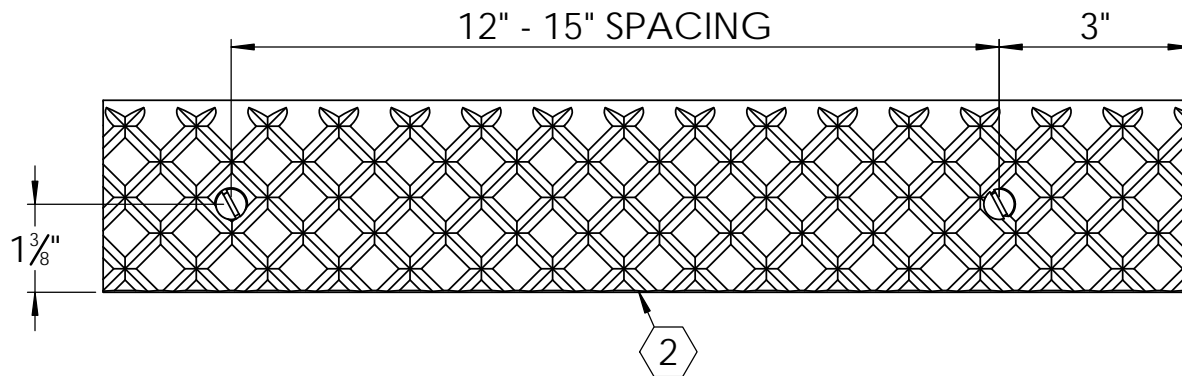

A

A

**SPECIFICATIONS:**

- ① BASE: 319 CAST ALUMINUM
- ② ABRASIVE: SILICON CARBIDE ABRASIVE , CROSSHATCH PATTERN 1/8" DEEP
- 3. FINISH: SAND CAST
- 4. POURED CONCRETE STAIRS: NOSING SHALL TERMINATE NO MORE THAN 3" FROM SIDE OF STEPS
- 5. LENGTH: 6" MINIMUM 6'-0" MAXIMUM
- 6. WING ANCHORS: SHIPPED LOOSE, STEEL ANCHORS AND STAINLESS STEEL HARDWARE

LENGTH ±1/8	QTY

PROJECT:				
ARCHITECT:				
CONTRACTOR:				
QTY:				
PART#:		STCA-C3W		
 9300 73rd Avenue North Minneapolis, MN 55428		TITLE:		
		STAIR TREAD, CAST SERIES 3", CAST ALUMINUM CROSSHATCH SHORT NOSING FOR CONCRETE, WING ANCHOR		
NAME	DATE	SIZE	DWG. NO.	REV
DRAWN DKL	10/13/23	A	STCA-C3W	E
RELEASED GLN	10/13/23	WEIGHT: 1.20 LB/FT		SHEET 1 OF 1

PROPRIETARY AND CONFIDENTIAL: THE INFORMATION CONTAINED IN THIS DRAWING IS THE SOLE PROPERTY OF NYSTROM. ANY REPRODUCTION IN PART OR AS A WHOLE WITHOUT THE WRITTEN PERMISSION OF NYSTROM IS PROHIBITED.