

B

B

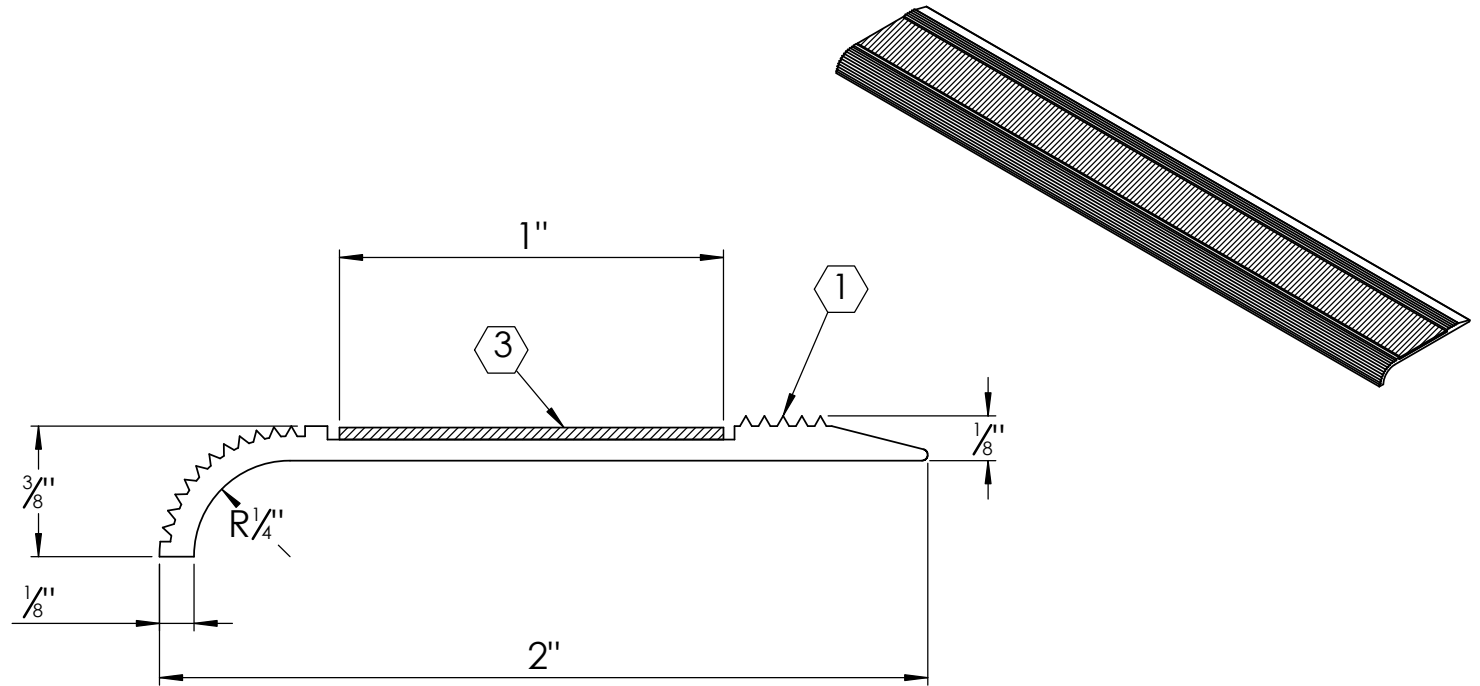

MODEL STRM-R2A-T

A

A



PROJECT:				
ARCHITECT:				
CONTRACTOR:				
QTY:				
PART#:				
 9300 73rd Avenue North Minneapolis, MN 55428		TITLE: Stair Tread, Renovation Low Profile, Round Nose Serrated Alum Body, 1" Insert		
		NAME	DATE	SIZE
DRAWN	DKL	7/26/18	A	Nystrom STN STRM-R2A-T ShpDr
RELEASED	TR	7/26/18	WEIGHT: -	REV A